

1. Introduction to Wearable Computers

Ever since the development of the ENIGMA (the first digital computer), computers have inspired our imagination. In this period came the World War II code breaking machine designed by Alan Turing, and Von Neuman's ENIAC which can be called dinosaurs compared to present day PCs. In the earlier days, computers were so huge that it took an entire building, or at least a floor to occupy one. Computers of that era were very slow by today's standards. In the non-ending struggle to increase computing speed, it was found out that speed of electricity might become a limiting factor in the speed of computation, and so it was a need to lessen the distance that electricity had to travel in order to increase the computing speed. This idea still holds true in modern computing.

By the 1970s, computers grew fast enough to process an average user's applications. But, they continued to occupy considerable amount of space as they were made of solid blocks of iron. The input was done by means of punch cards, and later came the keyboard, which revolutionalized the market. In 1971 came the 4004, a computer that was finally small in size. The programmability of these systems were quite less. Still, computers had to be plugged directly in to AC outlets, and input and output done by punch cards. These computers were not built keeping users in mind. In fact, the user had to adjust himself with the computer.

This was the time when wearable computer (wearcomp) was born. In the 1970s, wearcomp challenged the other PCs with its capability to run on batteries. Wearcomps were a new vision of how computing should be done. Wearable computing showed that man and machine were no more separate concepts, but rather a symbiosis. The wearcomps could become a true extension of one's mind and body.

In the beginning of 1980s, personal computing emerged. IBM's PC and other cheaper clones spread world-wide like fire. Finally the idea of a small PC on your desktop that costed you quite less became a reality. In the late 1980s PC's introduced the concept of WIMP (Windows, Icons, Mice & Pointers) to the world which revolutionalized the interface techniques. At the same time, wearables went through a

transformation of their own. They were now eyeglass based, with external eyeglass mounts. Though they remained visible to all, wearcomps were developing principles of miniaturization, extension of man's mind and body, secrecy and personal empowerment. Now, the only thing needed was an environment for them to flourish. People began to realize that wearcomps could be a powerful weapon in the hands of an individual against the machinery.

The 1990s witnessed the launch of laptops. The concept was a huge success as people could carry their PC wherever they go, and use them any time they need. A problem remained still. They still had to find a workspace to use their laptops since keyboards and mice (or touch-pads) remained.

During all these years of fast transformation, there remained visionaries who struggled to design computers that were extension of one's personality, computers that would work with your body, computers that will be with you at all times, always at your disposal. In the last two decades, wearcomps grew smaller still. Now you have completely covert systems which would reside inside your average glasses.

One of the prevalent ideas in wearable computing is the concept of mediated reality. Mediated reality refers to encapsulation of the user's senses by incorporating the computer with the user's perceptive mechanisms, which are used to process the outside stimuli. For example, one can mediate their vision by applying a computer-controlled camera to enhance it. The primary activity of mediated reality is direct interaction with the computer, which means that computer is "in charge" of processing and presenting the reality to the user. A subset of mediated reality is augmented reality. It differs from the former because interaction with the computer is secondary. The computer must be able to operate in the background, providing enough resources to enhance but not replace the user's primary experience of reality. Wearable computers have many applications centered around this concept of mediated / augmented reality as well as many other exciting applications centered around the idea of immediate access to information.

1.1. Definition of “Wearable Computer”

Wearable computing facilitates a new form of human-computer interaction comprising a small body-worn computer that is always on and always ready and accessible. In this regard, the new computational framework differs from that of hand held devices, laptop computers and personal digital assistants (PDAs). The “always ready” capability leads to a new form of synergy between human and computer, characterized by long-term adaptation through constancy of user-interface.

1.2. What is a Wearable Computer?

A wearable computer is a computer that is engulfed into the personal space of a user, controlled by the user, and has both operational and interactional constancy. Most notably, it is a device that is always with the user, and into which the user can always enter commands, and execute a set of such entered commands, and in which the user can do so while walking around or doing other activities. i.e. The wearcomp is a intertwined computer. Unlike wristwatches, regular eyeglasses, wearable radios, etc. the wearcomps are reconfigurable as the regular desktop PCs. Wearable computing can be defined in terms of its three basic modes of operation and its six fundamental attributes.

2. Operational modes

There are three operational modes in this new interaction between human and computer:

- **Constancy:** The computer runs continuously, and is “always ready” to interact with the user. Unlike a hand-held device, laptop computer, or PDA, it does not need to be opened up and turned ON prior to use. The signal flow from human to computer, and computer to human, runs continuously to provide a constant user-interface. The schematic is depicted above.

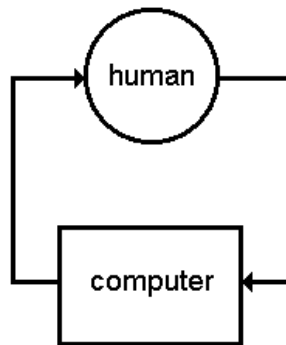

- **Augmentation:** Traditional computing paradigms are based on the notion that computing is the primary task. Wearable computing, however, is based on the notion that computing is NOT the primary task. The assumption of wearable computing is that the user will be doing something else, at the same time doing the computing. Thus the computer should serve to expand the intellect, or expand the senses. The signal flow between human and computer is depicted above.

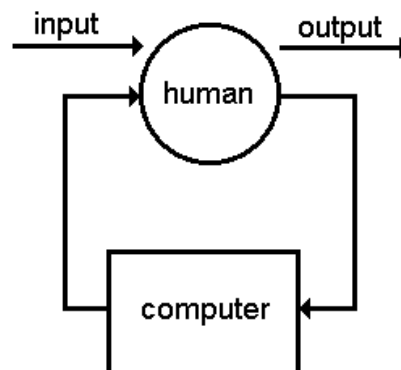

- **Mediation:** Unlike hand held devices, laptop computers, and PDAs, the wearable computer can encapsulate us. It doesn't necessarily need to completely enclose us, but the concept allows for a greater degree of encapsulation than traditional portable computers.

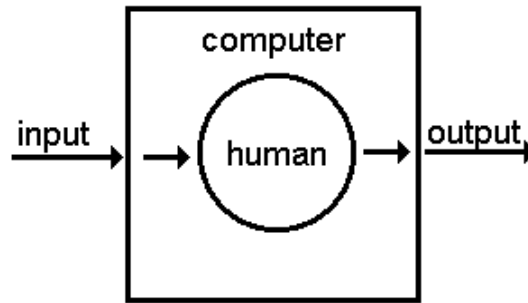

There are two aspects to this encapsulation:

- **Solitude:** It can function as an information filter, and allow us to block out material we might not wish to experience, whether it be offensive advertising, or simply a desire to replace existing media with different media. In less severe manifestations, it may simply allow us to alter our perception of reality in a very mild sort of way.
- **Privacy:** Mediation allows us to block or modify information leaving our encapsulated space. In the same way that ordinary clothing prevents others from seeing our naked bodies, the wearable computer may, for example, serve as an intermediary for interacting with untrusted systems, such as third party digital anonymous cash “cyberwallet”. In the same way that martial artists, especially stick fighters, wear a long black robe that comes right down to the ground, in order to hide the placement of their feet from their opponent, wearable computing can also be used to clothe our otherwise transparent movements in cyberspace. Although other technologies, like desktop computers, can help us protect our privacy with programs like Pretty Good Privacy (PGP), the Achilles tendon of these systems is the space between us and them. It is generally far easier for an attacker to compromise the link between us and the computer (perhaps

through a so-called trojan horse or other planted virus) than it is to compromise the link between our computer and other computers. Thus wearable computing can be used to create a new level of personal privacy because it can be made much more personal, e.g. so that it is always worn, except perhaps during showering, and therefore less likely to fall prey to covert attacks upon the hardware itself. Moreover, the close synergy between the human and computers makes it harder to attack directly, e.g. as one might peek over a person's shoulder while they are typing, or hide a video camera in the ceiling above their keyboard. Furthermore, the wearable computer can take the form of undergarments that are encapsulated in an outer covering or outerwear of fine conductive fabric to protect from an attacker looking at radio frequency emissions. The actual communications between the wearer and other computers (and thus other people) can be done by way of outer garments, which contain conformal antennas, or the like, and convey an encrypted bit stream.

Wearable computing is a framework which allows the combination of various degrees of these three fundamental modes. Collectively, the space of possible signal flows giving rise to this entire space of possibilities, is depicted below.

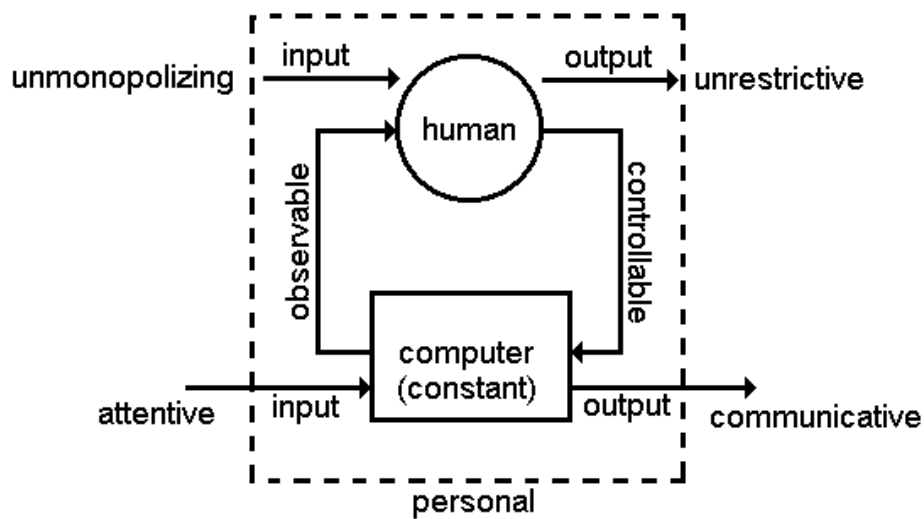

2.1. The six attributes of wearable computing

There are six informational flow paths associated with this new human – machine synergy. These signal flow paths are called attributes of wearable computing, and are described below.

1. **Unmonopolizing of the user’s attention:** It doesn’t cut you off from the outside world like a virtual reality game does. You can attend to any other job while using the apparatus. It is built keeping in mind that computation is a secondary activity, giving attention primary importance. In fact, it can provide you with enhanced sensory capabilities.
2. **Unrestrictive to the user:** Ambulatory, mobile etc... i.e. you can do other things while using it. E.g.: You can type while jogging, etc.
3. **Observable by the user:** It can get your attention continuously if you want it to. The screen is visible throughout, except when you close your eyes.
4. **Controllable by the user:** Highly responsive. You can grab control of it at any time you wish. Even automated processes can be broken, so that the user can be a part of the loop any time he wants to. E.g.: A HALT button can serve in stopping the loop being executed when files are opened one behind the other when you press the “return” key after selecting a block of files.
5. **Attentive to the environment:** Environmentally aware, multisensory. As a result, this gives the user increased situational awareness.
6. **Communicative to others:** Can be used as a communication medium when you want it to. It doesn’t block you from expressing your feelings.

Implied by the above six properties, it must also be:

- **Constant:** Always ready. May have sleep modes, but never dead. Unlike a laptop computer that must be opened up, switched on, and booted up before use, it is always ON and always running.
- **Personal:** Human and computer are inextricably intertwined.

- **Prosthetic:** You can easily adapt to it so that it acts as an extension of mind and body that you tend to forget that you are using it after a certain period of time.
- **Assertive:** Can have prohibition to requests by others for removal during times when you wish such a barrier. This is in contrast to laptop computer in a briefcase, or bag that could be separated from you by a “please leave all bags and briefcases at the counter” policy of a department store, library or similar establishment.
- **Private:** Others can’t observe or control it unless you let them to. Others can’t determine system status unless you want them to. E.g.: Clerk at a department store where photography is prohibited can’t tell whether or not you are transmitting wireless video to your spouse for remote advice, in contrast to camcorder technology where it is obvious that you are taking a picture when you hold it up to your eye.

3. Aspects of wearable computing and personal empowerment

There are several aspects and affordances of wearable computing. They are discussed in brief below:

- **Photographic memory:** Perfect recall of previously collected information.
- **Shared memory:** In the collective sense, two or more individuals may share their collective consciousness, so that one may recall information from another individual.
- **Connected collective humanistic intelligence:** In a collective sense, two or more individuals may collaborate while one or more of them is doing another primary task.
- **Tether less operation:** Wearable computers affords and requires mobility, and hence the freedom from the need to be connected by wire to an electrical outlet, or communications line.
- **Synergy:** In Artificial Intelligence (AI), the attempt is made to emulate human intelligence in the computer. But the goal of wearable computing is to produce a synergistic combination of human and machine, in which the human performs tasks that it is better at, while the computer performs tasks that it is better at. Over an extended period of time, the wearable computer begins to function as a true extension of the mind and body, and no longer feels as if it is a separate entity. In fact, the user will often adapt to the apparatus to such a degree that, when taking it off, its absence will feel uncomfortable, in the same way that we adapt to shoes, and clothing to such a degree that being without them most of us would feel extremely uncomfortable. This intimate and constant bonding is such that the combined capabilities of the resulting synergistic whole far exceed the sum of the either. This kind of synergy, in which the human being and

computer become elements of each other's feedback loop, is often called Humanistic Intelligence (HI).

- **Quality of life:** Wearable computing is capable of enhancing day to day experiences, not just in the workplace, but in all facets of daily life. It has the capability to enhance the quality of life for many people.

3.1. Augmented Memory

One of the key differences between a wearable computer and the currently available palmtops is that wearables are always operational, tend to have sensors into their environment, and tend to have the ability to get information to the wearer even when the wearer doesn't expect it. This opens the door to a whole range of augmented memory applications specifically for wearable computers.

A simple example of augmented memory would be a traditional scheduling program which alerted you just before important meetings. Your wearable would simply whisper the information in your ear, or flash it to a heads-up display. More interesting are applications similar to the Remembrance Agent (RA) system being worked on by Bradley Rhodes, which as a user types or walks around continuously looks for documents with content relevant to the user's current situation. The file names or salient lines from these correlated documents are then continuously displayed at the bottom of the user's word processor in order of similarity. The system can find similarity based on the words currently being typed, people currently present, current location, and other physical information. On a wearable equipped with sensors like GPS, an indoor location system, face recognition, and speech recognition, the RA can give information based not only on what the wearer is typing but also based on his or her physical environment. For example, on meeting someone at a trade show or conference it could remind the wearer who this person was, what their vital information is, and bring up the notes taken at the last meeting with this person.

The RA can also be used to create a "group mind" by sharing databases of files. For example, the annotations and corrections one student makes over the course of a term may be very valuable to another student. The RA can index other people's notes, and automatically bring up their notes and expertise whenever it is most relevant to me. This can be especially useful for knowledge transfer and on-the-job training for new workers.

3.2. Taming the monster with a piece of itself

Wisely designed technology can properly address the concerns for humanistic property, and therefore need not be focused on external control. In fact, the fundamental use of wearable computing may very well be the personal empowerment of the individual. Wearable computing will allow us to explore the full potential of many modern technologies and ideas without requiring us to sacrifice our freedom or privacy. Instead of the current vision of "smart floors", "smart light switches", "smart toilets", "smart elevators", "smart furniture", and other smart technologies that watch us and respond to our actions, what we will witness is the emergence of "smart people".

Smart cards and Active badges

The "smart card" systems common now a days provide an example of how smart clothing can replace the current surveillance infrastructure. Smart card systems replace keys with electronic access cards, which are swiped on a door mounted card reader to unlock the door. A similar technology uses badges that are tracked by the environment. Both the card key and active badge systems rely on a "smart" element built into the architecture (card reader or IR receiver) and a "dumb" element (card or beacon) carried or worn by the user. The "smart" element is networked to a central computer system, while the "dumb" element has no communications or networking capability.

Suppose we swap the two. Suppose that the user carries or wears the "smart" element, and the building architecture is endowed with the "dumb" element. Thus for example, the user might wear the Infra Red (IR) receiver, and have this connected to his "smart clothing", while numerous beacons would be distributed throughout the building.

This means that there is no need to network the beacons, no need to wire the building. The system relies on the communication infrastructure each user wears. However, the location of the user is now known to the user's clothing, and thus the user has control over who can and cannot know his location. A user might, for example define an access control list comprising faculty advisor, thesis advisor, colleagues, etc. The user's clothing would automatically encrypt the user's location (as determined by the last beacon seen by the user's clothing) and transmit this information to the desired recipients. Any interception of this communications would be unintelligible to those not on the access control list.

However, there are wearables, which work against the wearer. For instance, by denying the locus of control, some wearable technology works "against" rather than "for" the wearer. This technology is made use to enslave, imprison, or control the wearer. Tracking devices, such as active badges, may be used to monitor the location of a prisoner. Some devices have the capability of providing an "electrical corrective signal" (euphemism for cruel, pain-giving electric shock). Even wearable computers whose programs cannot be analyzed, or changed could potentially work against the user. Hence, the user should be able to re-program the computer whenever necessary. For example, the system should have complete source code for all its functions (in the context of the present invention, the Linux Operating System is used, which includes source code for everything including the Kernel). Note that all users would not have the time or ability to fully understand the complete source code. Under the user's control, the wearable computer is not a tool of governments or corporations, but a technology, which empowers the individual.

4. Operational details

“How do you operate a wearcomp?”, “What sort of OS / software do you use in it?”, “What do you use as input & output devices?”, “Where do you store data?”, “How do you build one?” – all these are common questions that would arise in someone new to wearcomps. Below given are brief answers to such common questions.

4.1. Software:

The commonly used Operating System on a wearable computer is the WOS (WearComp OS). Redhat and GNU Linux can be run in close coordination as an Operating System too. Various softwares, mostly GNU freeware such as GIMP (GNU Image Manipulation Program), XV, emacs etc as well as various calendar and planning programs can be run on a wearable computer.

4.2. Hardware:

Cost:

Prices of wearable computers tend to be in “thousands of dollars”, whether you buy or build. An alternative approach is to assemble a low cost system. For example, you can obtain an older computer that has NTSC output and connect it to a small CRT from a camera viewfinder. Some such complete wearable computer systems have been built for as little as \$20.

Display:

A major part of the total cost of a wearable computer lies in its display unit. Using VGA display tends to increase the cost of the system to a very high extend. So, in the design of cheaper models, NTSC resolution is used. This normally is too low to display a VGA image. There are many good video camera viewfinders that can display 24 rows of 80 characters each. While many of the modern LCD viewfinders are not capable of 80 x

24 text, there are a good many older black and white viewfinders that can display a sharp and clear 80 x 24 screen.

One of the commonly used display device nowadays is the **Personal Monitor**. The Personal Monitor is a unique eyeglasses mounted display that creates a high-resolution color image in the user's eyesight. The PM presents a video image equivalent of 26" screen from 6.5ft distance. The image covers only 5% of vision and allows seeing the surroundings also. The PM is easy to use, it can be plugged into the video source and power in seconds and the image will appear on the ultra lightweight display

PM before it is put on....

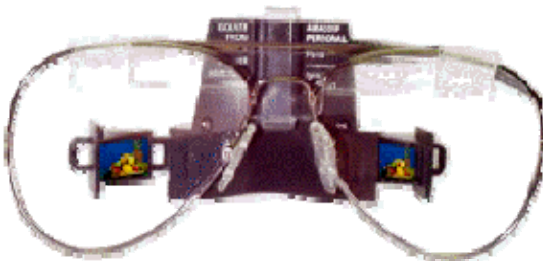

And after



Features :

- High-resolution colour video image
- Image that appears in the person's line of sight
- Viewing angle comparable to viewing a 26" monitor from 2 meters (6.5 feet) away
- Ultra light-weight, no major disturbance in the eyesight

The Personal Monitor (PM) projects a high resolution color video image that appears in the person's line of sight in a viewing angle comparable to viewing a 26" monitor from 2 meters away. The video image is see-around, it covers only the area where the image appears, and otherwise users are free to view the surrounding environment. The Personal Monitor provides an added convenience by maintaining the image the viewer is looking. While the PM provides a constantly available image in the person's line of sight, it enables to maintain focus and attention it keeps the integrity of the surrounding environment. The advantage will be immediate in decreased processing time and in increased precision. The Personal Monitor is a monoscopic biocular display with a relatively narrow field of view. The Personal Monitor can receive video signals from any video source. The signals are converted in the controller unit into signals driving the electronics of the LCD displays. The PM takes standard video signals and displays them on a small TFT LCD display that can be connected to any standard video source.

The PM consists of a monitor block, eyeglasses, cable and controller box. The monitor block contains the display, a backlight and its driver for the LCD, and a system of lenses and mirrors that project the display image into the retina of the eyes. The light beams coming from the display are reflected in two directions by the dividing mirrors placed in front of the display. The monitor block has a mounting slot that fits into the vertical nose piece of the eyeglasses. The controller box contains the video input demodulator unit and the driving electronics of the LCD display. The LCD direct display control signals are sent through a flexible shielded cable to the display. The eyeglasses have adjustable temple pieces and each unit comes with a commercially available 9V AC-DC adapter.

Keyboard:

If you are going on the cheap, collections of pushbutton microswitches are used as keyboards. At the higher end, you can get a “twiddler” from Handkey, or “BAT” keyboard from Infogrip. You can connect micro switches that enable you to plug directly into the keyboard port if you use a “BAT” keyboard.



twiddler 2

A combination keyboard and mouse that weighs 4 ounces and fits in the palm of your hand. The Twiddler2 is an enabling technology of wearable computing.

Hard drive:

Many hard drives commonly used in laptop computers can withstand 100G operational shocks. It is common to go jogging while editing, and sometimes shoot documentary video while on horseback, or riding a mountain bike down the center of a railway line bumping over every railway tie, and capturing the experience on a hard drive. Its possible to carry enormous amount of hard drive space on your body. Prof. Steve Mann, of MIT, has 36GB of hard drive installed in his underwear. One of his waist bag systems has 72GB of hard drive space and 512MB of RAM. Both IDE and SCSI interfaced hard drives are available.

5. Batteries for WearComp

Past/low cost: lead-acid batteries

Early versions of WearComp used lead-acid batteries. Later (Mid '80s) versions used NiCad batteries.

Lead-acid batteries are typically available surplus (e.g. taken out of used surplus equipment or the like). For constant operation you will want to obtain at least two 12 volt batteries. These batteries typically have lugs that connect to crimp-on connectors. However, in wearable applications, the lugs are easily broken off or shorted (fire/explosion hazard) by stray materials such as keys or tools one might be carrying in a pocket with the batteries. Therefore, wires were generally soldered right to the lugs, and insulated these very well.

Be sure to place a fuse right next to one of the lugs of the battery, not in the cord going to the battery. The reason for this is that if the fuse is in the cord, something can wear through the insulation on the cord upstream of the fuse, and cause a fire/explosion or the like.

The best fuses to use are the automotive type that have solder lugs. Place a fuse right near the positive lug, as close as possible. Typically one lug of the fuse can be soldered right to the positive lug of the battery. Now solder a red wire to the other end of the fuse, and solder a black wire to the negative lug of the battery. Wrap both lugs in several layers of fiberglass tape and epoxy. It is important to totally encase both the positive lug, and the fuse near it, wrapping all the way around the entire battery for strength, as general wear and tear on wearable apparatus is much higher than for other uses.

NiCad batteries

The use of surplus NiCad batteries is not recommend as NiCad batteries are generally very susceptible to ``memory" effects and other possible malfunction. Consequently, those found in salvage equipment are generally found in a state of malfunction already.

A new ``battery vest" may be used This solution has the advantage of providing a ready-to-wear power supply without the need to devise one's own solution. Furthermore, the vest provides plenty of pockets for placement of computational apparatus, etc., and provides a good means of physical placement of the additional components. These vests are designed for high-current output (e.g. video lights and large cameras), so it is advisable to include an additional fuse of lower current rating, consistent with the actual usage patterns expected.

Alternatively, one can purchase new NiCad packs and sew them into a vest or the like. Again, make sure the batteries are fused properly and well insulated as there is an extreme fire hazard owing to their high short-circuit current capability, and the potential hazard is multiplied by the effect of close proximity to the body, and potential difficult of removing the apparatus or undressing quickly enough to avoid being trapped in burning material.

Present/high performance: Li-Ion batteries

In the early to mid 1990s, people began to use lithium ion (Li-Ion) batteries. Most notably, now that Li-Ion camcorder batteries are commercially available, their use is recommend. You will need a minimum of four batteries (two sets of two in series) for a constant-running 12 volt supply. These camcorder batteries have built in female mini banana connectors. Therefore, to connect to WearComp, which has historically used banana connectors (all versions of WearComp since 1985 have used banana plugs), the following cables are useful (one set for each pair of batteries):

- One white cable, approx. 8 inches long, with a white mini banana plug on each end.
- One red cable, approx. 8 inches long, with a red mini male banana plug on one end, and a red regular-sized female banana socket on the other.
- One black cable, approx. 8 inches long, with a black mini male banana plug on one end, and a black regular-sized female banana socket on the other.

This facilitates connection of each battery in the pair in series (using the white wire), and adaptation to the standard banana connectors of the rig. Alternatively, the adaptor and the power bridge described in the next subsection, may be subsumed into a single entity.

While the choice of connectors is arbitrary, banana connectors were advocated initially (among small groups of people) so that all can share common batteries, chargers, etc., and also because they make field repairs simple (e.g. when wires break off while on long trips away from the workshop or lab). However, care is needed, as these connectors should be held together with gaffer's tape or the like, to prevent gradual separation in the clothing, resulting in exposed conductors. The purchase of three rolls of gaffer's tape in red, white, and black, and the use of appropriate colors is suggested to make sure that correct polarity is visible at all times.

5.1. Voltage regulator usage requirements

The weight, for a given energy level, is much less for Li-Ion batteries compared to lead-acid and NiCad batteries, but the output voltage of Li-Ion batteries varies widely, and drops significantly, with usage from a full charge. Lead acid batteries exhibit this nonconstancy of output voltage to some degree (compared to NiCads which are much more self-regulating), but Li-Ion batteries are far worse in this regard, and therefore, almost certainly, need a voltage regulator.

Another reason that a voltage regulator is needed is that various components of WearComp require different voltages. Typically the computational apparatus requires 5

volts while the analog video circuits, and the RF components require 12 volts. It is desirable that a single battery power the entire rig.

With the exception of WearComp0-3, all current versions of WearComp use 12 volt batteries. The original reason for this voltage selection arose from the automotive battery voltage standard, so that WearComp could be operated from an automobile cigarette lighter or accessory outlet fitted with a long cord, either for testing, or for additional runtime when the batteries were low. Furthermore, because much of the peripheral radio equipment operated at 12 volts, this voltage was convenient.

Accordingly, a single "12 volt" battery is used to power most of the apparatus, together with a voltage regulator to bring the 12 volts down to 5 for powering the computational portion of the apparatus.

A linear voltage regulator is undesirable, due to the dissipation of excess heat, since much more efficient switching regulators are available.

Regulators may be compared by:

1. linear versus integrated switching regulators (ISRs);
2. isolated versus 3 terminal

The most efficient are the non-isolated stepdown ISRs.

Furthermore, the voltage variation of Li-Ion batteries is typically excessive for certain components, which require exactly 12 volts, so it is often desirable to have separate switching regulators, one to provide 5 volts, and another to provide 12 volts. A so-called "step down" regulator is generally used to provide 5 volts for the computational apparatus, and a 12v to 12v regulator to take in the varying battery voltage and provide a fixed 12v output for other devices (video, radio, etc.). Furthermore, it is often desirable to use separate regulators for individual components, so that they don't affect each other.

5.2. Power Supply

Isolation is not needed, therefore a nonisolated (e.g., ``3 terminal") integrated switching regulator may be used. In particular, the PowerTrends PT6302 (3 amp ISR) which is much more efficient than the isolated regulators may be selected (e.g. Datel, etc.). Not only does this result in extended battery life, but also much less heat is produced by it.

WearComp6 is generally built from the Ampro CoreModule, together with various other modules. Most of the other modules do not have a power connector; power is connected only to the CoreModule, and the other boards derive their power through the interconnecting pins. The CoreModule has a 10 pin (or on some older versions, an 8 pin) power connector. The power connector provides both 5 volt and 12 volt connection terminals. However, most modern boards do not require the 12 volt connection, so you generally only need to connect 5 volts to the core module.

6. Building your own Wearcomp:

Different kinds of wearcomps are available. You can build one if you want to. The assembling of the “WearComp 6” is shown below.

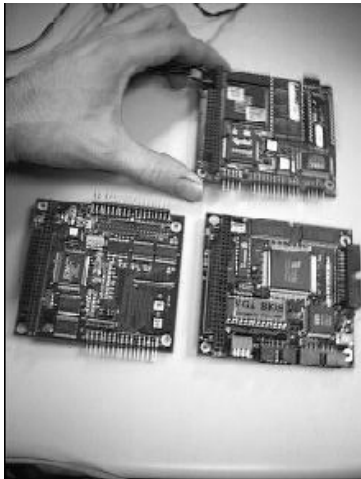

(a)

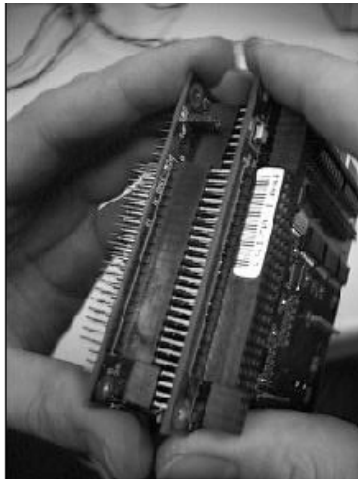

(b)

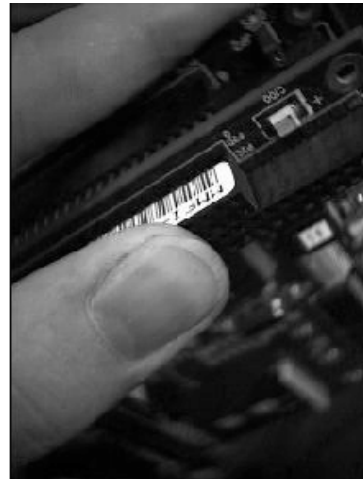

(c)

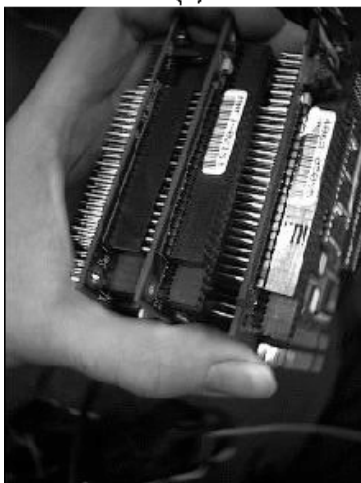

(d)

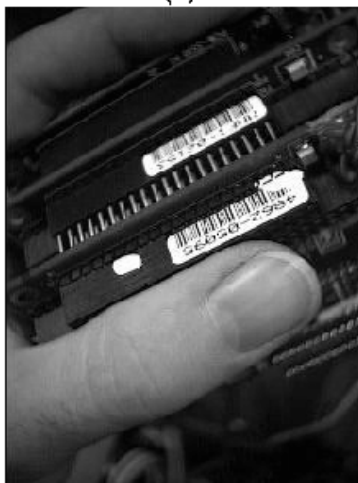

(e)

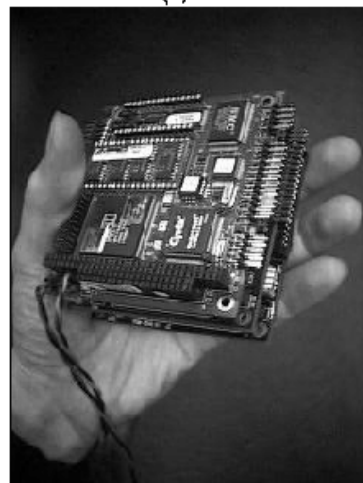

(f)

- a) Pictured here are boards from an early version of WearComp6 that required a separate floppy disk and IDE controller.
- b) Put the first two boards together; carefully insert pins from one, into the other.
- c) Once pins are aligned, press the first two boards together.
- d) If a third board is going on your stack, align it next.
- e) Press the new board together onto the rest of the stack.
- f) You now have a battery-operable multimedia computer in the palm of your hand.

7. Flash lamps for Cyber – photography

As discussed earlier, the user sees the outside world in symbiosis with the computer. Thus, by using flash lamps, cyber – photographs, and cyber – videos of whatever images that flow across the screen can be taken. Hence, a user can recall the past scenes from the computer memory. A discussion of wearable computing would not be complete without a look at electronic flash systems, and their control by wearable computers.

7.1. Modern commercial electronic flash systems

One of the most common, and best electronic flash available is the Lumedyne system. It is crude, simple, and reliable and is also the world's most powerful wearable electronic flash that you can buy commercially. Wearable electronic flash from Norman systems is also available. Unless you want to build your own wearable, the Lumedyne is probably the best choice. Many wedding photographers use the Lumedyne system, and you will also see these systems worn by professional photographers doing on-location work. The basic unit contains eight 400-microfarad capacitors and a circuit to charge them to 480 volts. This unit is housed in a plastic case with a shoulder strap. The Lumedyne system is mostly preferable because of several reasons. Some of them are discussed below.

- Since the whole unit is enclosed inside a plastic case, if anything goes wrong with the system, there won't be any metal touching the user's body. The Lumedyne system is so safe that it uses only plastic screws on the top. Moreover, the Lumedyne system doesn't radiate appreciably strong electromagnetic signals.
- The Lumedyne system is cruder and simpler in its design, and is therefore easier to modify, and is more reliable.
- The Lumedyne system is expandable. For example, Lumedyne sells additional plastic boxes each containing an additional eight 400-

microfarad capacitors, for an additional 400J of energy. These additional boxes snap together to build up the unit. Up to three additional boxes, which provide a total of 1600J can be worn comfortably, and allow a safety margin by staying well below the 2400J maximum rating of the flash tube.

7.2. Smaller flash lamps

The Lumedyne and Norman are both wearable. Some smaller units are hand held, rather than wearable. So, the user can select the one he wants depending up on his own comfort. Some of the best ones available are:

- a. Metz Mecablitz
- b. Braun 900
- c. Braun 920

The Mertz has three models viz. 45KX-6, 50MZ-5, 60CT-4. The Metz model numbers indicate the guide distance in meters. Unlike the Lumedyne, the Metz has one big capacitor rather than several small ones. In stroboscopic mode, running at 30 Hz, the frame rate is suitable for an NTSC wearable camera video capture. Models 45 and 50 both have the capacitor in the handle, whereas model 60 uses a bodywork capacitor, battery, and an oscillator.

8. Applications of Wearable Computers:

Almost anything and everything in computing is born first as a theoretical approach, almost a dream in the mind of the inventor. Some of such theories have clear practical applications, such as encryption algorithms. Others on the other hand, take some time to evolve from the concepts on paper to something that can be applied in the real world. The transistor is the best example of this. Legend has it that Bell Labs' engineers almost failed to register the patent on what turned out to be the concept that revolutionized computers.

Having the above in mind, it is not surprising to ask "What are wearable computers good for?" and "Can I do something useful with this thing?" Perhaps the strongest reason one should respond with "Many things" and "Yes, you can!" lies in the origin of wearable computing. Lack of functionality was what made the inventors explore what could be done about it, and eventually to make wearable computers more functional than their counterparts. Now, we'll take a look at the applications of wearable computers.

8.1. Mediated / Augmented reality:

It is the ability of the computer to offer enhanced presentations of reality to the user. Face recognition programs utilizing Fourier analysis have long been around. Imagine bumping into someone you have met only once, and immediately knowing not only their name, but having access to a whole database of information about them. Other applications of augmented reality lie in adding to your perceptual field. To aid in repairing a broken photocopier, an overlay of the internal structure of the photocopier can be put in the repair person's visual field, and thus can help him in his work.

8.2. Blind Vision:

Visually challenged, or impaired persons can benefit much from Blind Vision. It is a personalized radar system that is integrated in close – fitting vest and which is able to

process objects in the vicinity of the wearer. Returned waves from the said object are transformed by the wearable computer and sent over to the vest, which sends electric stimuli to the wearer. The exact position of the moving object with respect to the wearer is stimulated, as well as the proximity: Closer objects exhibit stronger “pressure” via stronger current, while object further away accordingly output milder current. In the very real sense, one can experience what would be described as the sensory vision. Blind Vision does not only apply to visually challenged persons: Any cyclist, motorcyclist, or professional who has to work on the open environment would appreciate this invention.

8.3. MediWear:

MediWear is closely related to Blind Vision, but with an interesting twist. Where Blind Vision is involved with processing the outside stimuli, and presenting them introspectively, MediWear does the opposite. Clothes with embedded wearable computers closely monitor the wearer’s body functions. The moment that any one of them becomes critical, the predefined medical unit is notified remotely. The paradigm of Blind Vision is then inverted, as the transmitted signals are internal and they are relayed on to an external source.

8.4. ENGwear:

Another application of wearable computers following the approach of MediWear is ENGwear, the acronym which stands for Electronic News Gathering Wearable system. As with MediWear, the introspective impressions of the wearer are forwarded to an external source. This application, however, introduces something that all previous ones lacked: The sense of community. Whereas the user is treated as the individual both in Blind Vision and in MediWear, ENGwear implies the existence of a group to which the user might want to offer his or her sensory impressions. Just about anything that the wearer would see at a given moment could be shared. The usefulness of this paradigm of wearable computing is more than obvious.

Having listened only several applications that come to mind, one can easily see why you would have to answer positively to the questions posed at the beginning of this section. It is clear that wearable computing as a concept has survived its fragile infancy as a theoretical approach and furthermore, that the exciting era of applied research is in hand. The current rate of expansion in the field suggests that there will be many more inventions in the near future.

9. Disadvantages:

Current systems are not waterproof, and must be removed prior to showering. Most of the time, one wears the system during most of the waking hours. Sometimes it is worn during sleeping, especially “crashing” at some place where it is not possible to undress or change clothes. Ironically, one often becomes so accustomed to the hard drive activity that one will wake up from a deep sleep if there is something wrong with the system (e.g. Power failure or total inactivity of the hard drive)

The virtual image of the display is quite far away, and in fact, if it is adjusted so that parallel rays of light enter the eye, then one experiences light equivalent to an infinitely large image, infinitely far away. Eye damage from excessively bright light, over extended time periods, is however still a problem, but dark glasses can help to minimize strain.

Batteries have to be changed once, twice, or even thrice a day depending up on how much equipment is being used at a time.

Wearable computers, as they grow smaller and smaller in size might be used illegally by many. For example, a student might use it inside an examination hall to recall all stored data inside and write his exams to score high. An anti-socialist might use it to crawl into places where photography is banned, or where confidential papers are kept.

10. Future Developments

Of course, many view wearcomps as a gadget. In fact, the days when a wearcomp user looked weird among the society is over. The launch of mobile phones was seen with curved eyebrows in many countries including India. But in two years time, it has become a common appliance among everyone. Just as a mobile phone user gets adapted to his handset, and doesn't feel any discomfort in carrying it around (he might have felt so in the beginning), any wearcomp user will end up the same way.

Covert systems, in the 1990's made the first step toward making it possible to look normal, and to be connected. The launch of Covert Wearcomp (Wearcomp 7) is a major leap in the wearcomp technology. Currently, the so-called "underwearable computers" makes it possible to be wired without looking weird.



Prof. Steve Mann wearing Covert wearcomp, "the under wearable"

References

1. Bass, L. et al. *The Design of a Wearable Computer*. Proceedings CHI'97, Atlanta, GA; 1997.
2. Abowd, G.D.; Dey, A.K.; Orr, R.; Brotherton, J. *Context-awareness in Wearable and Ubiquitous Computing*. Proc. 1 st ISWC '97, Boston, MA, 1997.
3. <http://wearables.about.com>
4. <http://www.cs.cmu.edu/afs/cs.cmu.edu/project/vuman/www/home.html>
5. <http://www.media.mit.edu/projects/wearables/>
6. <http://www.cs.uoregon.edu/research/wearables/Oregon/>
7. <http://wearables.gatech.edu/>
8. <http://www.media.mit.edu/projects/wearable/timeline.html>
9. <http://www.it.kth.se/labs/ccs/ws/ws.html>

Evolution of Steve Mann's "wearable computer" invention



Evolution of Mann's "Wear Comp" invention from WearComp2 to WearComp7



Steve Mann, wearing his "Smartpants" together with Wearcomp 3 in 1980's



IBM's new Wearable PC

Key specifications include:

- **CPU:** Intel MMX Technology Pentium - 233MHz; 256KB External L2 Cache
- **Memory (RAM):** 64MB(EDO)
- **Video:** Subsystem NeoMagic MagicGraph128XD
- **Video RAM:** 2MB
- **HDD:** IBM Micro Drive 340MB
- **Interface (Port):** USB
- **Infrared:** Max 4Mbps(IrDA V1.1)
- **Compact Flash Card Slot:** Type2 x 1
- **Audio:** Microphone, Earphone, SoundBlaster Pro Compatible
- **Micro Display:** 320x240 pixels 256 grayscale (SVGA Color under development)
- **Battery:** Li-Ion (1.5-2 hours)
- **Size:** 26(H) mm x 80(W) mm x 120(L) mm
- **Weight:** 299g (System Unit with Battery Pack),50g (Headset), 20g (Track Point Unit)
- **Operating System:** Windows98/95