

INTRODUCTION

Explosive information demand in the internet world is creating enormous needs for capacity expansion in next generation telecommunication networks. It is expected that the data-oriented network traffic will double every year.

Optical networks are widely regarded as the ultimate solution to the bandwidth needs of future communication systems. Optical fiber links deployed between nodes are capable to carry terabits of information but the electronic switching at the nodes limit the bandwidth of a network. Optical switches at the nodes will overcome this limitation. With their improved efficiency and lower costs, Optical switches provide the key to both manage the new capacity Dense Wavelength Division Multiplexing (DWDM) links as well as gain a competitive advantage for provision of new band width hungry services. However, in an optically switched network the challenge lies in overcoming signal impairment and network related parameters. Let us discuss the present status, advantages and challenges and future trends in optical switches.

OPTICAL FIBERS

A fiber consists of a glass core and a surrounding layer called the cladding. The core and cladding have carefully chosen indices of refraction to ensure that the photos propagating in the core are always reflected at the interface of the cladding. The only way the light can enter and escape is through the ends of the fiber. A transmitter either alight emitting diode or a laser sends electronic data that have been converted to photons over the fiber at a wavelength of between 1,200 and 1,600 nanometers.

Today fibers are pure enough that a light signal can travel for about 80 kilometers without the need for amplification. But at some point the signal still needs to be boosted. Electronics for amplitude signal were replaced by stretches of fiber infused with ions of the rare-earth erbium. When these erbium-doped fibers were zapped by a pump laser, the excited ions could revive a fading signal. They restore a signal without any optical to electronic conversion and can do so for very high speed signals sending tens of gigabits a second. Most importantly they can boost the power of many wavelengths simultaneously.

Now to increase information rate, as many wavelengths as possible are jammed down a fiber, with a wavelength carrying as much data as possible. The technology that does this has a name-dense wavelength division multiplexing (DWDM) – that is a paragon of technospeak.

Switches are needed to route the digital flow to its ultimate destination. The enormous bit conduits will flounder if the light streams are routed using conventional electronic switches, which require a multi-terabit signal to be converted into hundreds of lower-speed electronic signals. Finally, switched signals would have to be reconverted to photons and reaggregated into light channels that are then sent out through a designated output fiber.

The cost and complexity of electronic switching prompted to find a means of redirecting either individual wavelengths or the entire light signal in a fiber from one path way to another without the opto-electronic conversion.

OPTICAL SWITCHES

Optical switches will switch a wavelength or an entire fiber-form one pathway to another, leaving the data-carrying packets in a signal untouched. An electronic signal from electronic processor will set the switch in the right position so that it directs an incoming fiber – or wavelengths within that fiber- to a given output fiber. But none of the wavelengths will be converted to electrons for processing.

Optical switching may eventually make obsolete existing lightwave technologies based on the ubiquitous SONET (Synchronous Optical Network) communications standard, which relies on electronics for conversion and processing of individual packets. In tandem with the gradual withering away of Asynchronous Transfer Mode (ATM), another phone company standard for packaging information.

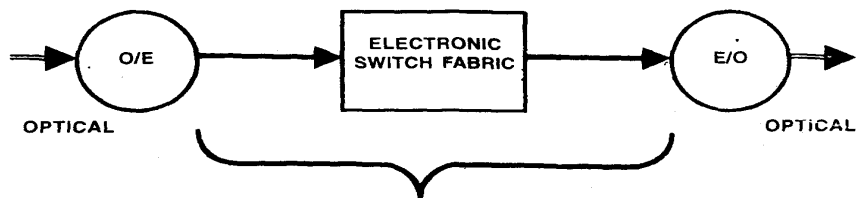

(A) INTELLIGENT O-E-O SWITCH



(B) ALL OPTICAL SWITCH

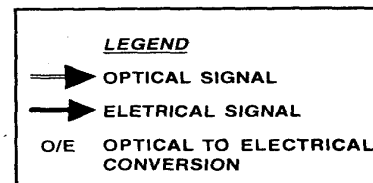

Optical Switches

MEMS

Introduction

Micro-electro Mechanical Systems or MEMS is a new process for device fabrication, which builds “micromechines” that are finding increasing acceptance in many industries ranging from telecommunications to automotive, aerospace, consumer electronics and others.

In essence, MEMS are Mechanical Integrated circuits, using photo lithographic and etching processes similar to those employed in making large scale integrated circuits – devices that are deposited and patterned on a silicon-wafer’s surface.

Construction

In MEMS, oxide layers are etched away to sculpt the device’s structural elements. Instead of creating transistors, though, lithographic processes built devices a few tens or hundreds of microns in dimension that move when directed by an electrical signal. Silicon mirrors are manufactured by self-assembly- a novel step that takes its name from the way amino-acids in protein molecules fold themselves into three-dimensional shapers. In the final stage of manufacture, tiny springs on the silicon surface release the mirrors and a frame around each on lifts them and locks them in place, positioning them high enough above the surface to allow for a range of movement.

Working

Software in the switch's processor makes a decision about where an incoming stream of photons should go. It sends a signal to an electrode on the chip's surface that generates an electric field that tilts the mirrors. The wavelengths bounce off the input mirrors and get reflected off another mirror onto output mirrors that direct the wavelength into another fiber. Switches with 256 incoming fibers and same number of outgoing fibers have been successfully tested and employed.

Analogy

To understand the working of switch, consider a room with many windows and a movable mirror inside. On manipulating the mirror, the sunlight streams through a window could be reflected off the desired window.

Advantages

1. Fast

No opto-electronic conversion, so the entire process lasts a few milliseconds, fast enough for the most demanding switching applications. The above switch offered more than 10 terabits per second of total switching capacity, with each of the channels supporting 320 GB per second – 128 times faster than current electronic switches. Eventually such switches might support the petabit (quadrillion-bit) systems that are looming on the horizon.

2. Size

Each mirror in one MEMS switch is half a millimeter in diameter, about the size of the head of a pin. Mirrors rest one millimeter apart and all 256- mirrors are fabricated on a 2.5 centimeter-square piece of silicon. The entire switch is about the size of a grape- fruit –32 times denser than an electronic switch.

3. Power reduction

With no processing, or opto-electronic conversion, these switches provide a 300-fold reduction in power consumption over electronic switches.

4. Economical

Standard silicon circuit manufacturing processors make the technology cost effective.

5. Larger Switches

The design of mirror-arrays uses one mirror for input and one for output. Coupled with the VLSI technique, they promote building of much larger switches.

6. Stability

Silicon microns afford greater stability than if the mirrors were fabricated from metal.

7. Accurate

Use of silicon fabrication technology results in stiffer mirrors that are less prone to drifting out of alignment and which are robust, long lived and scalable to large number of devices on wafer. Superior-Software control algorithms let the individual elements manipulated precisely.

8. Well-matched to optics application

The technology is also well matched to optics applications – because easily accommodates the need to expand or reconfigure the number of pathway through the switch.

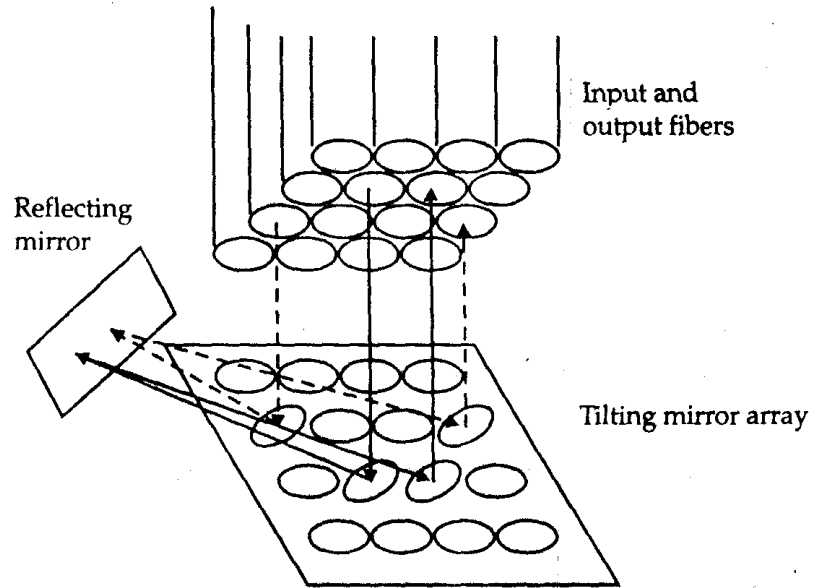

Principle of MEMS optical switch operation

THERMO-OPTIC SWITCH

The MEMS is not the only way to produce an optical switch architecture that uses many small and inexpensive components to control the flow of light from input to output. One interesting approach is to use what are known as Thermo-optical waveguides. Waveguides can be built by the some standard process used to make integrated circuits and so like “fibers on a chip”. Waveguides have a core and cladding made of glass with differing indices of refraction, just like normal fiber optic cables.

The basic Thermo-optical switching element has an input waveguide and two possible output waveguides. In between there are two short, internal waveguides that first split the input light and then couple the two internal waveguides together again. The recombined light would proceed down the “default” output waveguide. But thermo-optical effect makes it possible to use this coupling of the light as a switching element.

Working

The general principle of thermo-optical switching element is shown in the figure. An input light wave is split onto two separate waveguides. If no heat is applied to the lower branch in the figure, the coupler will output the waveform on to the waveguide labeled output#1 in the figure. The figure shows the heating element activated, and a slightly different phase induced into the waveform on the lower

branch. So the output light wave does not take the default waveguide but ends upon the waveguide labeled output#2 instead.

Advantages

Because they can be built on a common material substrate like silicon, waveguides tend to be small and inexpensive, and they can be manufactured in large batches. The substrates, called wafers, can serve as platforms to attach lasers and detectors that would enable transmission or receipt of optical pulses that represent individual bits. Integration of various components could lead to photonic integrated circuit, a miniaturized version of the components that populate physics laboratories, one reason the waveguide technology is sometimes called a **SILICON OPTICAL BENCH**

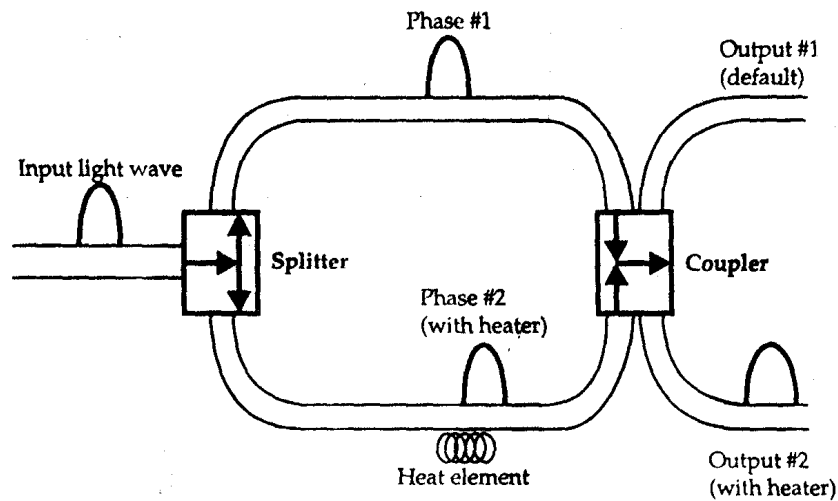

The general principle of thermo-optical switching elements

BUBBLE SWITCH

Construction and Working

The switch consists of a silica waveguide with arrays of intersecting light pipes that form a mesh. A small hole sits at a point where these light pipes intersect. It contains an index-matching fluid (one whose index of refraction is the same as the silica). So if no bubble is present at the junction, the light proceeds down the default waveguide path. If a bubble of fluid is present at the junction, the light is shifted onto the second output waveguide. The bubble acts as a mirror that reflects the light wave to another branch of the switching element. An ink-jet printing head underneath can blow a bubble into the hole, causing light to bend and move into another waveguide. But if no bubble is present, the light proceeds straight. That this switch works at all is a testament to the extraordinary sophistication of the fluid technology behind printers.

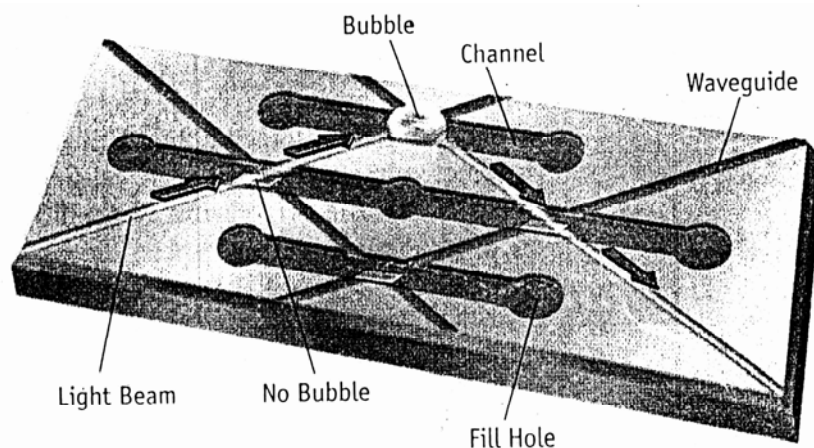

The general principle of the bubble optical switch

LIQUID CRYSTAL SWITCH

Even more people are familiar with the liquid crystal displays found in digital watches and some forms of computer output devices than are familiar with inkjet printers. Liquid crystals can also be used as a basis for optical switches as well. When an electrical field is applied to the liquid crystal, the molecules line up and so can become opaque.

The liquid crystal switches rely on a change in the polarization of optical signals with the application of electrical voltage to make a switching element. Because the liquid crystal molecules are so long and thin, they will let only light of a particular orientation pass through the liquid crystal.

Liquid crystal switching elements are built with two active components, the cell and the displacer. The liquid crystal cell is formed by placing the liquid crystals between two plates of glass. The glass is coated with an oxide material that conducts electricity and is also transparent. The glass plate form the electrodes of the cell portion of the switching element. The main function of the cell is to reorient the polarized light entering the cell as required. The displacer is a composite crystal that directs the polarized light leaving the cell. Light polarized in one direction is directed to one output waveguide by the displacer, while light polarized at a 90 degree angle is directed to a second output waveguide.

Working

The upper portion of the figure shows the path of a light wave when no voltage is applied to the cell. Input light of arbitrary polarization lines up with the default polarization orientation of the liquid crystals inside the cell. The displacer also has a default orientation and the light emerges as shown in the figure. The lower portion of the figure shows the path of a light wave when voltage is applied to the cell. Note that the liquid crystals in the cell and those in the displacer both change their orientation under the influence of the voltage. The polarized light now takes the second output path.

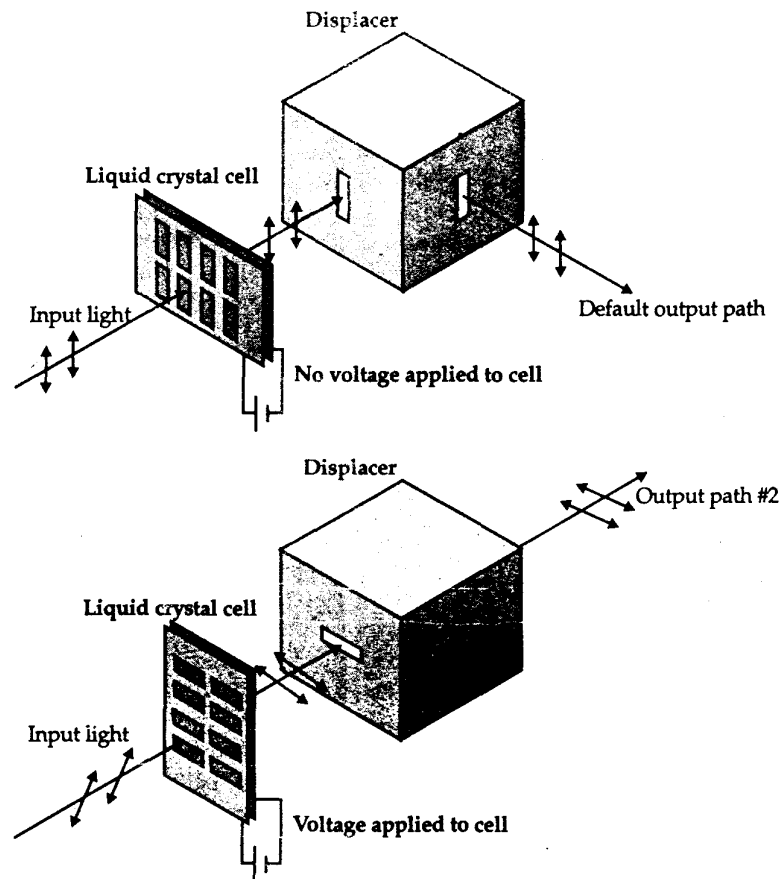

The general structure of the liquid crystal switching element

NON-LINEAR OPTICAL SWITCH

Another type of optical switch takes advantage of the way of the refractive index of glass changes as the intensity of light varies. Most of the optical phenomena in everyday life are linear. If more light is shined on a mirror, the surface reflects more of the incident light and the imaged room appears brighter.

A non-linear optical effect, however, changes the material properties through which the light travels. Mirror becomes transparent when more light is shined on it.

Glass optical fibers experience non-linear effects, some of which can be used to design very fast switching elements, capable of changing their state in a femtosecond (quadrillionth of a second time scale). Consider a non-linear optical loop mirror, a type of interferometer in which two light beams interact.

In the mirror a fiber splitter divides an incoming beam. In one instance each segment travels through the loop in opposite directions recombines after completing the circle and exist on the same fiber on which it entered the loop. In cases, though, after the two beams split, an additional beam is send down one side of the loop but not the other. The intensity of light produced by the interaction of the coincident beams changes the index of refraction in the fiber, which in turn changes the phase of the light. The recombined signal with its altered phase, exits out a separate output fiber.

In general, non-linear optical switching requires the use of very short optical pulses that contain sufficient power to elicit non-linear effects from the glass in the fiber. An optical amplifier incorporated into the switch, however, can reduce the threshold at which these non-linear effects occur. For the purpose of switching the intensity dependent phase change induced by the silica fiber itself could be used as the non-linearity. The pulse traversing the fiber loop clockwise is amplified by an EDFA shortly after it leaves the directional coupler.

This configuration is called Non-linear Amplifying Loop Mirror (NALM). The amplified pulse has higher intensity and undergoes a larger phase shift on traversing the loop compared to the unamplified pulse. Although non-linear switches have yet to reach commercial development, the technology shows promise for the future.

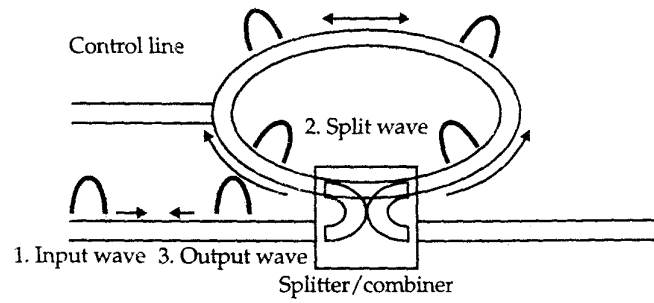
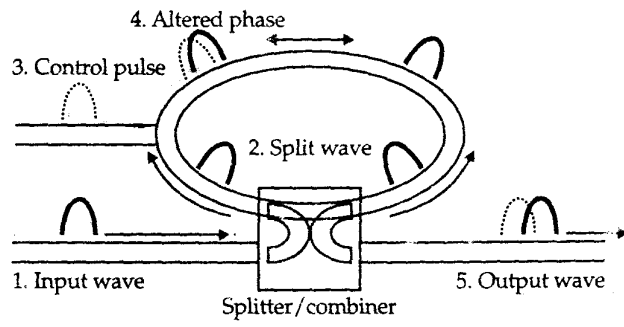

Nonlinear optical switching

CONCLUSION

Photonic packet – switched networks offer the potential of realizing packet-switched networks with much higher capacities than may be possible with electronic packet-switched networks. However, significant advances in technology are needed to make them practical, and there are some significant roadblocks to overcome, such as the lack of economical optical buffering and the difficulty of propagating very high speed signals at tens and hundreds of gigabits/second over any significant distances of optical fiber. There is a need for compact soliton light sources. At this time, fast optical switches have relatively high losses, including polarization-dependent losses, and are not amenable to integration, which is essential to realize large switches. Temperature dependence of individual components can also be a significant problem when multiplexing, demultiplexing, or synchronizing signals at such high bit rates.

BIBLIOGRAPHY

1. Rajiv Kumar, "Optical Switching", Telecommunications, Nov-Dec 2002.
2. Walter Goralski, Optical Networking and WDM, Tata Mc Grawhill edition.
3. Rajiv Ramaswami, Kumar N Sivarajan – Optical networks. A practical perspective.

ABSTRACT

Theoretically optical switches seem to be future proof with features of scalability, flexibility, bit rate and protocol independent coupled with lower infrastructure costs but a network service provider must evaluate the pros and cons and all possible options to select optimum combination of electronic and photonic switches to meet the capacity and traffic management requirements. This seminar presents an overview on optical switches.

- Optical switches including mems, bubble, Thermo-optical, Liquid crystal and non-linear optical switches have been discussed.
- Finally all optical switching a technology that's still in its infancy but holds tremendous potential, since it switches optical packets, is also with.

CONTENTS

1. INTRODUCTION	1
2. OPTICAL FIBERS	2
3. OPTICAL SWITCHES	4
• MEMS	5
• Thermo-optical waveguide	9
• Bubble Switch	11
• Liquid Crystal Switch	12
• Nonlinear Optical Switch	14
4. CONCLUSION	16
5. BIBLIOGRAPY	17

ACKNOWLEDGEMENT

I extend my sincere gratitude towards **Prof. P. Sukumaran** Head of Department for giving us his invaluable knowledge and wonderful technical guidance

I express my thanks to **Mr. Muhammed Kutty** our group tutor and also to our staff advisor **Ms. Biji Paul** for their kind co-operation and guidance for preparing and presenting this seminar.

I also thank all the other faculty members of AEI department and my friends for their help and support.