

## INTRODUCTION

An accurate electric current transducer is a key component of any power system instrumentation. To measure currents power stations and substations conventionally employ inductive type current transformers with core and windings. For high voltage applications, porcelain insulators and oil-impregnated materials have to be used to produce insulation between the primary bus and the secondary windings. The insulation structure has to be designed carefully to avoid electric field stresses, which could eventually cause insulation breakdown. The electric current path of the primary bus has to be designed properly to minimize the mechanical forces on the primary conductors for through faults. The reliability of conventional high-voltage current transformers have been questioned because of their violent destructive failures which caused fires and impact damage to adjacent apparatus in the switchyards, electric damage to relays, and power service disruptions.

With short circuit capabilities of power systems getting larger, and the voltage levels going higher the conventional current transformers becomes more and more bulky and costly also the saturation of the iron core under fault current and the low frequency

response make it difficult to obtain accurate current signals under power system transient conditions. In addition to the concerns, with the computer control techniques and digital protection devices being introduced into power systems, the conventional current transformers have caused further difficulties, as they are likely to introduce electromagnetic interference through the ground loop into the digital systems. This has required the use of an auxiliary current transformer or optical isolator to avoid such problems.

It appears that the newly emerged Magneto-optical current transformer technology provides a solution for many of the above mentioned problems. The MOCT measures the electric current by means of Faraday Effect, which was first observed by Michael Faraday 150 years ago. The Faraday Effect is the phenomenon that the orientation of polarized light rotates under the influence of the magnetic fields and the rotation angle is proportional to the strength of the magnetic field component in the direction of optical path.

The MOCT measures the rotation angle caused by the magnetic field and converts it into a signal of few volts proportional to the electric current. It consists of a sensor head located near the current carrying conductor, an electronic signal processing unit and fiber

optical cables linking to these two parts. The sensor head consist of only optical component such as fiber optical cables, lenses, polarizers, glass prisms, mirrors etc. the signal is brought down by fiber optical cables to the signal processing unit and there is no need to use the metallic wires to transfer the signal. Therefore the insulation structure of an MOCT is simpler than that of a conventional current transformer, and there is no risk of fire or explosion by the MOCT. In addition to the insulation benefits, a MOCT is able to provide high immunity to electromagnetic interferences, wider frequency response, large dynamic range and low outputs which are compatible with the inputs of analog to digital converters. They are ideal for the interference between power systems and computer systems. And there is a growing interest in using MOCTs to measure the electric currents.

## MOCT-PRINCIPLE

The Magneto-Optical current transformer is based on the Faradays effect. Michael Faraday discovered that the orientation of linearly polarized light was rotated under the influence of the magnetic field when the light propagated in a piece of glass, and the rotation angle was proportional to the intensity of the magnetic field. The concept of Faraday Effect could be understood from the Fig.1.

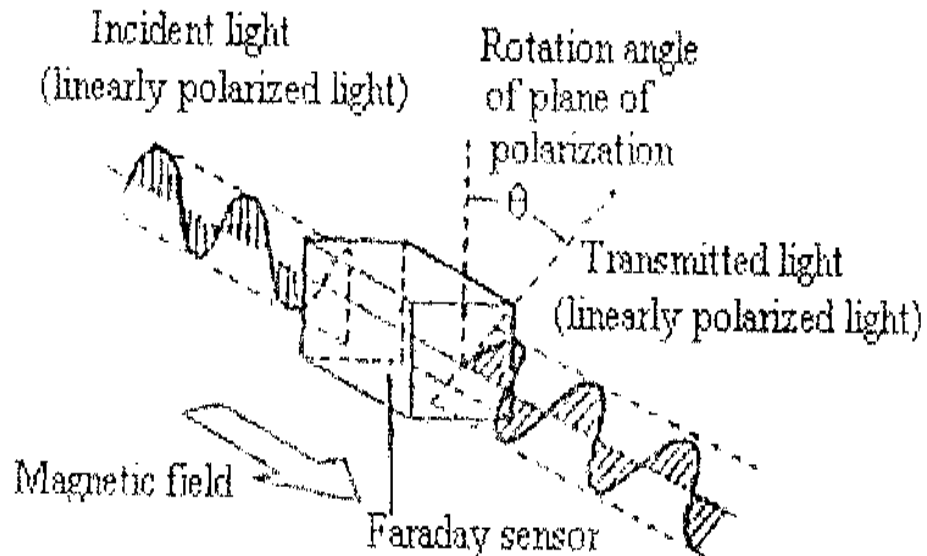

Fig. 1

Generally, this phenomenon can be described as follows:

$$\theta = V \int B \cdot dl \quad \dots\dots\dots \text{Eq(1)}$$

' $\theta$ ' is the Faraday rotation angle,

'V' is the Verdet constant of magneto-optical material

'B' is the magnetic flux density along the optical path

'l' is the optical path

When the linearly polarized light encircles a current carrying conductor eq(1) can be rewritten as according to Ampere's law as

$$\theta = n\mu VI \quad \dots\dots\dots \text{Eq(2)}$$

'I' is the current to be measured,

' $\mu$ ' is the permeability of the material,

'n' is the number of turns of the optical path.

The Faraday effect outlined in eq(2) is a better format to apply to an MOCT, because the rotation angle in this case is directly related to the enclosed electric current. It rejects the magnetic field signals due to external currents which are normally quite strong in power system.

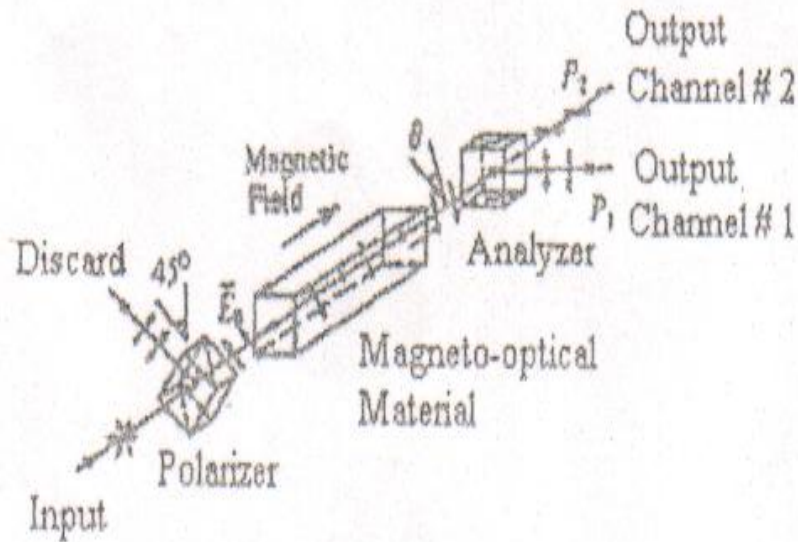

Fig. 2

The typical application of the Faraday effect to an MOCT is clear from fig(2). A polarizer is used to convert the randomly polarized incident light into linearly polarized light. The orientation of the linearly polarized light rotates an angle  $\theta$  after the light has passed through the magneto-optical material because of Faraday Effect. Then another polarization prism is used as an analyzer, which is  $45^\circ$  oriented with the polarizer, to convert the orientation variation of the polarized light into intensity variation of the light with two outputs, and then these two outputs are send to photo detectors. The purpose of using the analyzer is that photo detectors can only detect the intensity of light, rather than the orientation of polarizations. The output optical signals from the analyzer can be described as,

$$P_1 = \frac{P_0}{2}(1 + \sin 2\theta)$$

$$P_2 = \frac{P_0}{2}(1 - \sin 2\theta)$$

$P_0$  is the optical power from the light source,

$\theta$  is the Faraday rotation angle,

$P_1$  and  $P_2$  are the optical power delivered by the detectors.

In order to properly apply Eq(2) in the MOCT design by making the optical path wrap around the current carrying conductor, the optical path has to be folded by reflections. Total internal reflections and metal reflections are good ways to achieve this. However reflections introduce phase shift; hence change the polarization state of the light. The optical prism has to be designed to keep the light going through the MOCT linearly polarized. In order to stimulate the behavior of the polarized light reflect through the glass prism of an MOCT, ie to maintain the light traveling through the glass prism to be linearly polarized and also for the analysis of the effects of dielectric and metal reflections on the linearly polarized light, a computer programme is written in FORTARN language. Stimulation results include information such as polarization state change at each reflection and the overall responsibility of the optical sensor.

**DESIGN**

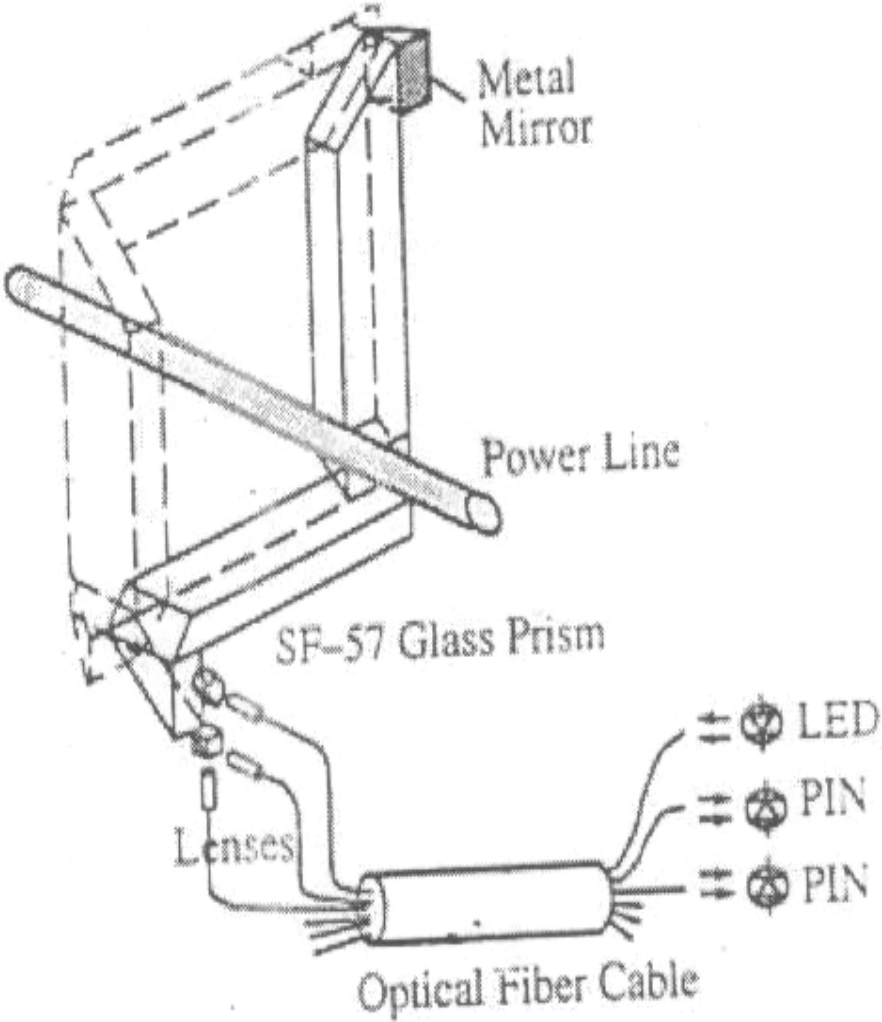

Fig. 3

Fig (3) shows the structure of this MOCT. The optical sensor consists of two separate clamp-on parts. In each part of the device, linearly polarized light is arranged to pass through the optical glass prism to pickup the Faraday rotation signal. The polarization

compensation technique is applied at each corner of the prisms, so that the light passing through the prism remains linearly polarized. At the other end of the prism, a silver mirror reflects the light beam so that light beam comes back to its sending end via the same route while accumulating the Faraday rotations.

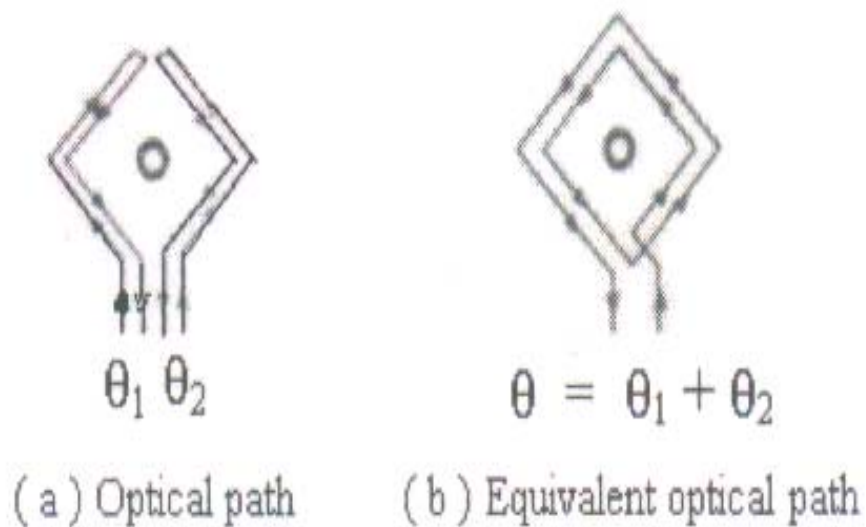

Fig. 4

The two halves can be assembled around the conductor. Thereby, the rotation angles from the two halves of the sensor [Fig.4(a)] are added up in the signal processing unit so that the total rotation angle ( $\theta_1 + \theta_2$ ) is the same as the rotation angle  $\theta$  from the optical path shown in Fig.4(b), which is two turns around the conductor.

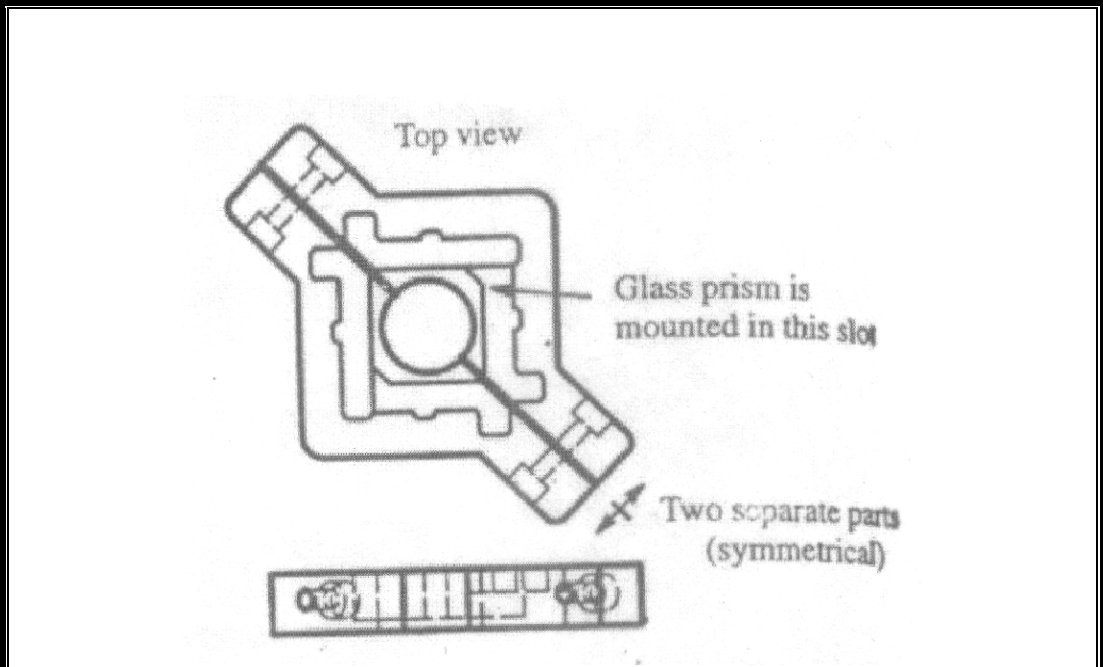

Fig. 5

Fig. 5 shows the structure of the housing for the clamp-on MOCT. The optical glass prism polarizes, and lenses are completely sealed in the housing by epoxy, so that they are free of environmental hazards such as dust and moisture. This structure avoids the use of magnetic material to concentrate the magnetic field as found in some other MOCT design and Hall Effect current measurement devices. There for it is free from the effect of remanent flux, which could affect the accuracy of the current measurement.

## MAGNETO-OPTICAL SENSOR

Almost all transparent material exhibits the magneto-optical effect or Faraday Effect, but the effect of some of the material is very temperature dependent, and they are not suitable for the sensing material. The optical glasses are good candidate for the sensing material, because the Verdet constants are not sensitive to the temperature changes, and they have good transparency properties. They are cheap and it is easy to get large pieces of them. Among the optical glasses SF-57 is the best choice, as it has larger Verdet constant than most of the other optical glasses. And MOCT made out of these materials can achieve higher sensitivity. In the MOCT, from Eq (2), the total internal rotation angle is,

$$\theta \approx \theta_1 + \theta_2 \approx 2\mu VI$$

Where I is the current to be measured,

$$\mu = 4\pi \times 10^{-7} \text{ H/m}$$

$$V = 7.7 \times 10^2 \text{ degrees/Tm at a wavelength of } 820\text{nm}$$

Therefore  $\theta = 1.9 \text{ degrees/ KA}$ .

Different optical fibers are designed for different usage. The single mode fiber has very wide bandwidth, which is essential for

communication systems, but it is difficult to launch optical power into the single mode fiber because of its very thin size. While large multimode fiber is convenient for collecting maximum amount of light from the light source, it suffers from the problem of dispersion which limits its bandwidth. In the situation of power system instrumentation, only moderate frequency response is required and in MOCT, the more optical power received by the detectors the better signal to noise ratio can be achieved. Therefore, the large core multi-mode optical fiber is used here to transfer the optical signals to and from the optical sensors.

## ELECTRONIC CIRCUIT FOR THE MOCT

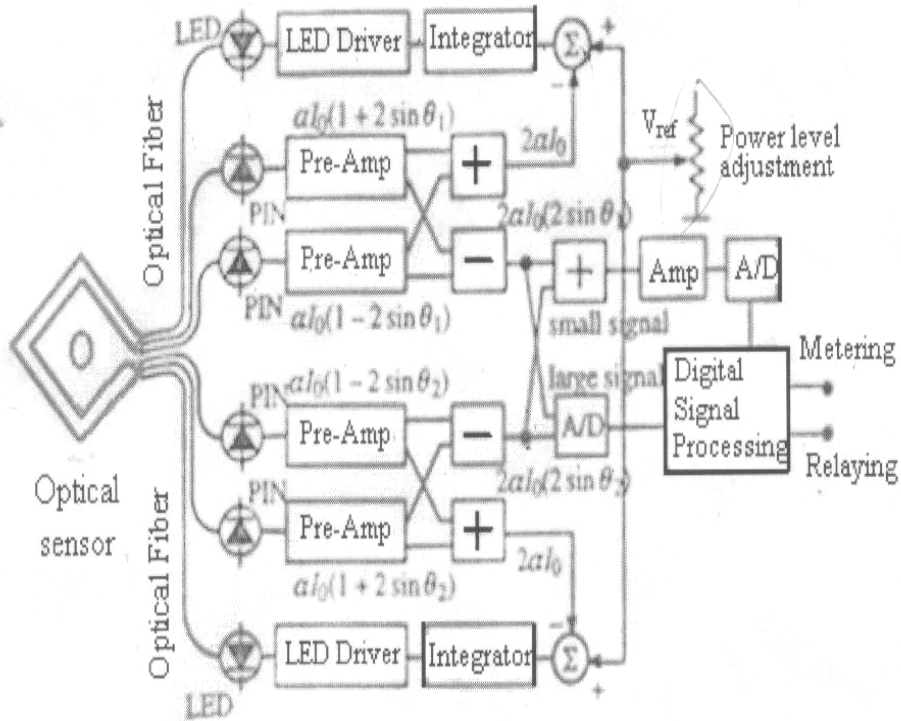

Fig. 6

Fig. 6 shows the schematic diagram of the electronic circuit for the clamp-on MOCT. In order to make use of the dynamic range of the digital system as well as the different frequency response requirements of metering and relaying, metering signal (small signal) and relaying signal (large signal) are treated differently. Two output stages have been designed accordingly. One stage, which has 1 KA dynamic range, is for power system current metering, and other stage,

which operate up to 20 KA, provides power system current signals for digital relay systems.

In each part of the device, the sum of the two receiving channels signals, which have the same DC bias  $\alpha I_0$ , differenced at junction with a reference voltage  $V_{ref}$  from the power level adjustment potentiometer. Then an integrator is used to adjust the LED driver current to maintain  $2\alpha I_0$  to be the same as the  $V_{ref}$  at the junction. Because the reference voltage  $V_{ref}$  is the same for both the sides, the DC bias  $\alpha I_0$  and the sensitivities  $2\alpha I_0$  of the two halves of the clamp-on MOCT are considered to be stable and identical.

The difference of the two receiving channels signals  $2\alpha I_0$  ( $2\sin\theta_1$ ) and  $2\alpha I_0$  ( $2\sin\theta_2$ ) in each part of the device are added directly and then fed through an amplifier for the small signals. At the same time these two signals are processed digitally to do a  $\sin^{-1}$  calculation on each and then summed together for the large signal situation when the non-linearity of the MOCT can no longer be ignored. The ratio responses of the two output stages of the clamp-on MOCT are designed as 10V/KA and 0.5V/KA and frequency responses are 4KHz and 40 KHz respectively.

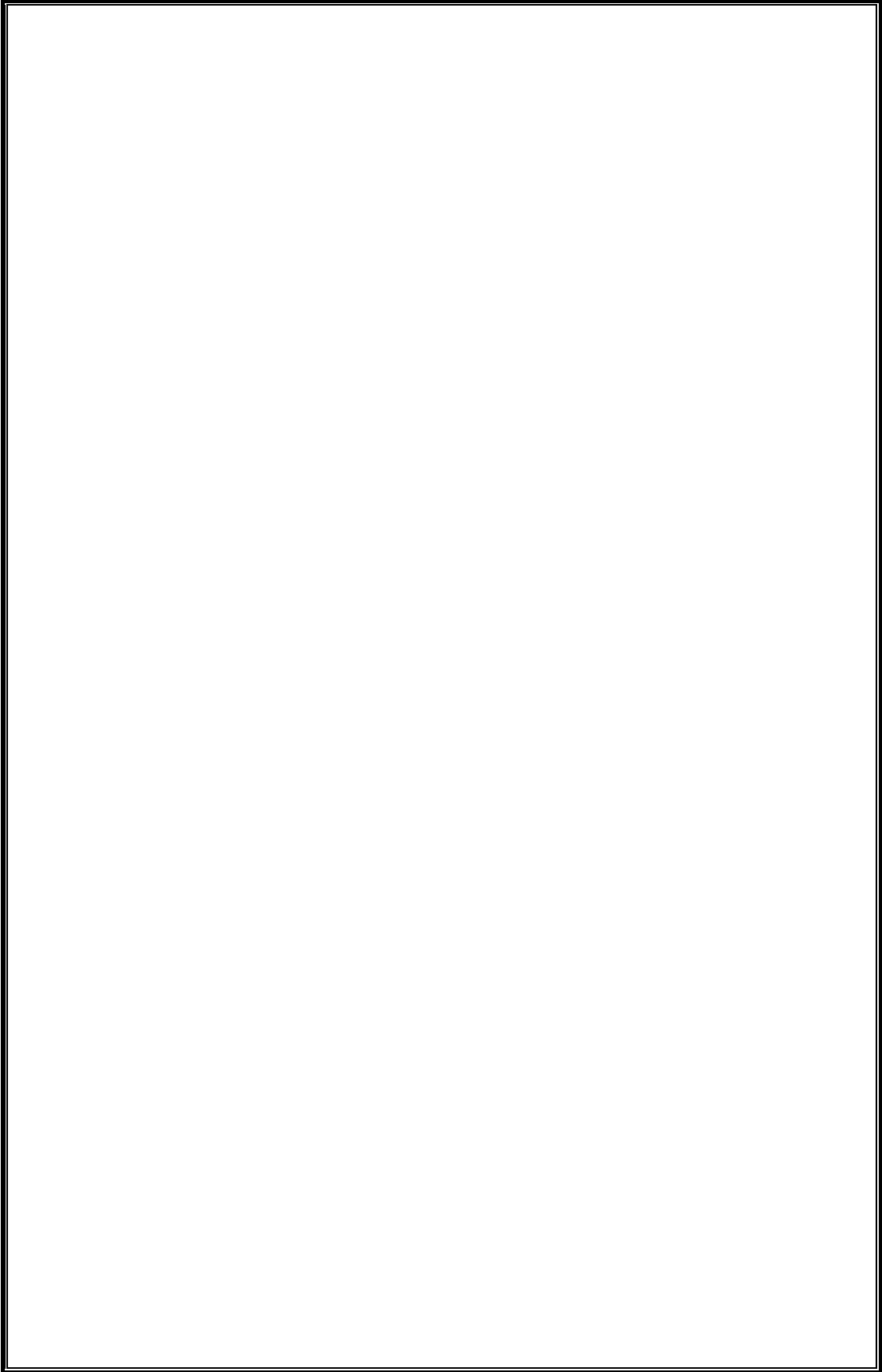

## **APPLICATION**

The MOCT is designed to operate in a transparent manner with modern electronic meters and digital relays, which have been adopted for a low energy analog signal interface. Typically, the design approach is to redefine the interface point as to input the analog to digital conversion function used by each of these measurement systems.

## **ADVANTAGES OF MOCT**

1. No risk of fires and explosions.
2. No need to use metallic wires to transfer the signal and so simpler insulation structure than conventional current transformer.
3. High immunity to electromagnetic interference.
4. Wide frequency response and larger dynamic range.
5. Low voltage outputs which are compatible with the inputs of digital to analog converters.

## **DISADVANTAGES OF MOCT**

1. Temperature and stress induced linear birefringence in the sensing material causes error and instability.
2. The accuracy of MOCT is so far insufficient for the use in power systems.

## CONCLUSION

This paper presents a new kind of current transducer known as magneto optical current transducer. This magneto optical current transducer eliminates many of the drawbacks of the conventional current transformers. In an conventional current transformers, there is a chance of saturation of magnetic field under high current, complicated insulation and cooling structure, a chance of electro magnetic interference etc.

By applying Faraday's principle this transducer provides an easier and more accurate way of current measurement. This MOCT is widely used in power systems and substations nowadays. And a new trend is being introduced, which known as OCP based on adaptive theory, which make use of accuracy in the steady state of the conventional current transformer and the MOCT with no saturation under fault current transients.

## BIBLIOGRAPHY

- Farnoosh Rahmatian ;patric p. chavez &Nicholas A.F “optical voltage transducers using multiple electric field sensors”. IEEE transactions on power delivery ,vol.17 april 2002
- J C Santos ,M.C Taplama Ciogle and K Hidak “Pockel’s High Voltage Measurement Systems” IEEE transactions on power delivery ,vol.15 jan 2000
- <http://www.iop.org/EJ/article>
- <http://www.cris-inst.com/publication/bejing>
- Physics for engineers by Premlet

## **ABSTRACT**

An accurate current transducer is a key component of any power system instrumentation. To measure currents, power stations and substations conventionally employ inductive type current transformers. With short circuit capabilities of power system getting larger and the voltage level going higher the conventional current transducers becomes more bulky and costly.

It appears that newly emerged MOCT technology provides a solution for many of the problems by the conventional current transformers. MOCT measures the rotation angle of the plane polarized lights caused by the magnetic field and convert it into a signal of few volts proportional to the magnetic field.

Main advantage of an MOCT is that there is no need to break the conductor to enclose the optical path in the current carrying circuit and there is no electromagnetic interference.

## CONTENTS

<b>1. INTRODUCTION</b>	<b>1</b>
<b>2. MOCT-PRINCIPLE</b>	<b>4</b>
<b>3. DESIGN</b>	<b>8</b>
<b>4. MAGNETO-OPTICAL SENSOR</b>	<b>11</b>
<b>5. ELECTRONIC CIRCUIT FOR THE MOCT</b>	<b>13</b>
<b>6. APPLICATION</b>	<b>15</b>
<b>7. ADVANTAGES OF MOCT</b>	<b>16</b>
<b>8. DISADVANTAGES OF MOCT</b>	<b>16</b>
<b>9. CONCLUSION</b>	<b>17</b>
<b>10. BIBLIOGRAPHY</b>	<b>18</b>

## ACKNOWLEDGEMENT

I extend my sincere gratitude towards **Prof. P.Sukumaran** Head of Department for giving us his invaluable knowledge and wonderful technical guidance

I express my thanks to **Mr. Muhammed Kutty** our group tutor and also to our staff advisor **Ms. Biji Paul** for their kind co-operation and guidance for preparing and presenting this seminar.

I also thank all the other faculty members of AEI department and my friends for their help and support.