

INTRODUCTION

There are various applications that require a 3D world to be simulated as realistically as possible on a computer screen. These include 3D animations in games, movies and other real world simulations. It takes a lot of computing power to represent a 3D world due to the great amount of information that must be used to generate a realistic 3D world and the complex mathematical operations that must be used to project this 3D world onto a computer screen. In this situation, the processing time and bandwidth are at a premium due to large amounts of both computation and data.

The functional purpose of a GPU then, is to provide a separate dedicated graphics resources, including a graphics processor and memory, to relieve some of the burden off of the main system resources, namely the Central Processing Unit, Main Memory, and the System Bus, which would otherwise get saturated with graphical operations and I/O requests. The abstract goal of a GPU, however, is to enable a representation of a 3D world as realistically as possible. So these GPUs are designed to provide additional computational power that is customized specifically to perform these 3D tasks.

WHAT'S A GPU???

A Graphics Processing Unit (GPU) is a microprocessor that has been designed specifically for the processing of 3D graphics. The processor is built with integrated transform, lighting, triangle setup/clipping, and rendering engines, capable of handling millions of math-intensive processes per second. GPUs form the heart of modern graphics cards, relieving the CPU (central processing units) of much of the graphics processing load. GPUs allow products such as desktop PCs, portable computers, and game consoles to process real-time 3D graphics that only a few years ago were only available on high-end workstations.

Used primarily for 3-D applications, a graphics processing unit is a single-chip processor that creates lighting effects and transforms objects every time a 3D scene is redrawn. These are mathematically-intensive tasks, which otherwise, would put quite a strain on the CPU. Lifting this burden from the CPU frees up cycles that can be used for other jobs.

However, the GPU is not just for playing 3D-intense videogames or for those who create graphics (sometimes referred to as graphics rendering or content-creation) but is a crucial component that is critical to the PC's overall system speed. In order to fully appreciate the graphics card's role it must first be understood.

Many synonyms exist for Graphics Processing Unit in which the popular one being the graphics card .It's also known as a video card, video accelerator, video adapter, video board, graphics accelerator, or graphics adapter.

HISTORY AND STANDARDS

The first graphics cards, introduced in August of 1981 by IBM, were monochrome cards designated as **Monochrome Display Adapters** (MDAs). The displays that used these cards were typically text-only, with green or white text on a black background. Color for IBM-compatible computers appeared on the scene with the 4-color **Hercules Graphics Card** (HGC), followed by the 8-color **Color Graphics Adapter** (CGA) and 16-color **Enhanced Graphics Adapter** (EGA). During the same time, other computer manufacturers, such as Commodore, were introducing computers with built-in graphics adapters that could handle a varying number of colors.

When IBM introduced the **Video Graphics Array** (VGA) in 1987, a new graphics standard came into being. A VGA display could support up to 256 colors (out of a possible 262,144-color palette) at resolutions up to 720x400. Perhaps the most interesting difference between VGA and the preceding formats is that VGA was analog, whereas displays had been digital up to that point. Going from digital to analog may seem like a step backward, but it actually provided the ability to vary the signal for more possible combinations than the strict on/off nature of digital.

Over the years, VGA gave way to **Super Video Graphics Array** (SVGA). SVGA cards were based on VGA, but each card manufacturer added resolutions and increased color depth in different ways. Eventually, the **Video Electronics Standards Association** (VESA) agreed on a standard implementation of SVGA that provided up to 16.8 million colors and 1280x1024 resolution. Most graphics cards available today support **Ultra Extended Graphics Array** (UXGA). UXGA can support a palette of up to 16.8 million colors and resolutions up to 1600x1200 pixels.

Even though any card you can buy today will offer higher colors and resolution than the basic VGA specification, VGA mode is the de facto standard for graphics and is the minimum on all cards. In addition to including VGA, a graphics card must be able to connect to your computer. While there are still a number of graphics cards that plug into an Industry Standard Architecture (ISA) or **Peripheral Component Interconnect (PCI)** slot, most current graphics cards use the **Accelerated Graphics Port (AGP)**.

PERIPHERAL COMPONENT INTERCONNECT(PCI)

There are a lot of incredibly complex components in a computer. And all of these parts need to communicate with each other in a fast and efficient manner. Essentially, a bus is the channel or path between the components in a computer. During the early 1990s, Intel introduced a new bus standard for consideration, the Peripheral Component Interconnect (PCI). It provides direct access to system memory for connected devices, but uses a bridge to connect to the front side bus and therefore to the CPU.

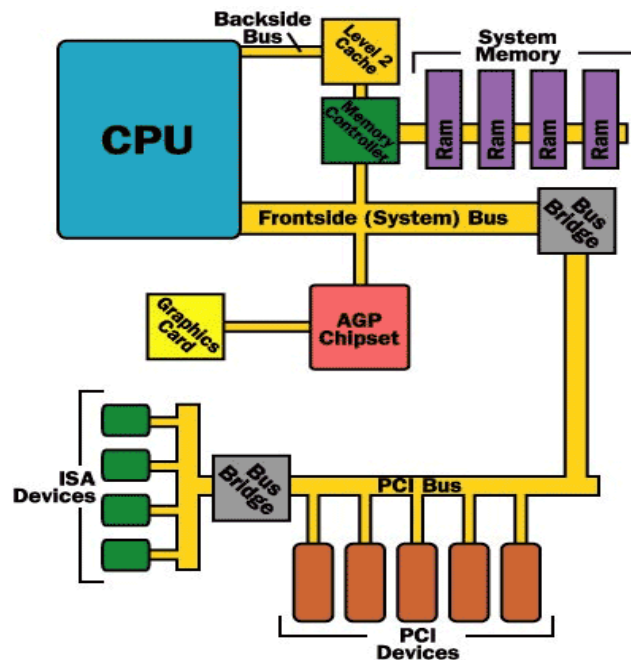

The illustration above shows how the various buses connect to the CPU.

PCI can connect up to five external components. Each of the five connectors for an external component can be replaced with two fixed devices on the motherboard. The PCI bridge chip regulates the speed of the PCI bus independently of the CPU's speed. This provides a higher degree of reliability and ensures that PCI-hardware manufacturers know exactly what to design for.

PCI originally operated at 33 MHz using a 32-bit-wide path. Revisions to the standard include increasing the speed from 33 MHz to 66 MHz and doubling the bit count to 64. Currently, PCI-X provides for 64-bit transfers at a speed of 133 MHz for an amazing 1-GBps (gigabyte per second) transfer rate!

PCI cards use 47 pins to connect (49 pins for a mastering card, which can control the PCI bus without CPU intervention). The PCI bus is able to work with so few pins because of hardware multiplexing, which means that the device sends more than one signal over a single pin. Also, PCI supports devices that use either 5 volts or 3.3 volts. PCI slots are the best choice for network interface cards (NIC), 2-D video cards, and other high-bandwidth devices. On some PCs, PCI has completely superseded the old ISA expansion slots.

Although Intel proposed the PCI standard in 1991, it did not achieve popularity until the arrival of Windows 95 (in 1995). This sudden interest in PCI was due to the fact that Windows 95 supported a feature called **Plug and Play (PnP)**. PnP means that you can connect a device or insert a card into your computer and it is automatically recognized and configured to work in your system. Intel created the PnP standard and incorporated it into the design for PCI. But it wasn't until several years later that a mainstream operating system,

Windows 95, provided system-level support for PnP. The introduction of PnP accelerated the demand for computers with PCI.

ACCELERATED GRAPHICS PORT (AGP)

The need for streaming video and real-time-rendered 3-D games requires an even faster throughput than that provided by PCI. In 1996, Intel debuted the **Accelerated Graphics Port (AGP)**, a modification of the PCI bus designed specifically to facilitate the use of streaming video and high-performance graphics.

AGP is a high-performance interconnect between the core-logic chipset and the graphics controller for enhanced graphics performance for 3D applications. AGP relieves the graphics bottleneck by adding a dedicated high-speed interface directly between the chipset and the graphics controller as shown below.

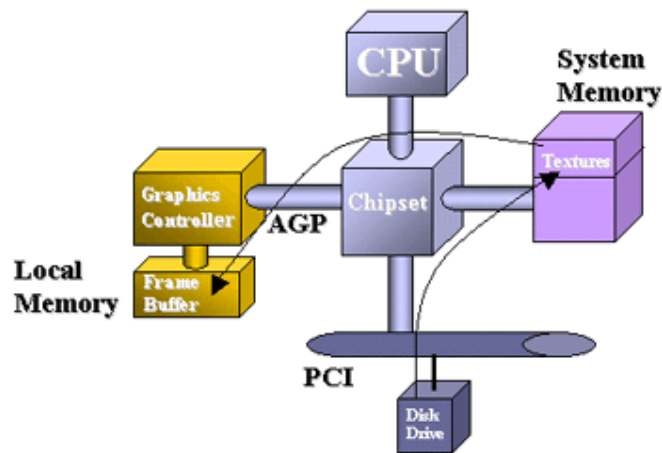

Segments of system memory can be dynamically reserved by the OS for use by the graphics controller. This memory is termed AGP memory or non-

local video memory. The net result is that the graphics controller is required to keep fewer texture maps in local memory.

AGP has 32 lines for multiplexed address and data. There are an additional 8 lines for sideband addressing. Local video memory can be expensive and it cannot be used for other purposes by the OS when unneeded by the graphics of the running applications. The graphics controller needs fast access to local video memory for screen refreshes and various pixel elements including Z-buffers, double buffering, overlay planes, and textures.

For these reasons, programmers can always expect to have more texture memory available via AGP system memory. Keeping textures out of the frame buffer allows larger screen resolution, or permits Z-buffering for a given large screen size. As the need for more graphics intensive applications continues to scale upward, the amount of textures stored in system memory will increase. AGP delivers these textures from system memory to the graphics controller at speeds sufficient to make system memory usable as a secondary texture store.

AGP Memory Allocation

During AGP memory initialization, the OS allocates 4K byte pages of AGP memory in main (physical) memory. These pages are usually discontinuous. However, the graphics controller needs contiguous memory. A translation mechanism called the GART (Graphics Address Remapping Table), makes discontinuous memory appear as contiguous memory by translating virtual addresses into physical addresses in main memory through a remapping table.

A block of contiguous memory space, called the Aperture is allocated above the top of memory. The graphics card accesses the Aperture as if it were main memory. The GART is then able to remap these virtual addresses to physical addresses in main memory. These virtual addresses are used to access main memory, the local frame buffer, and AGP memory.

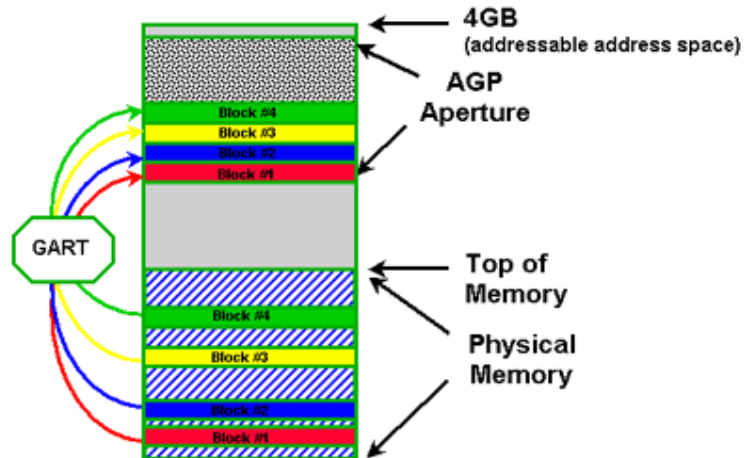

AGP Transfers

AGP provides two modes for the graphics controller to directly access texture maps in system memory: **pipelining and sideband addressing**. Using **Pipe mode**, AGP overlaps the memory or bus access times for a request ("n") with the issuing of following requests ("n+1"... "n+2"... etc.). In the PCI bus, request "n+1" does not begin until the data transfer of request "n" finishes.

With **sideband addressing (SBA)**, AGP uses 8 extra "sideband" address lines which allow the graphics controller to issue new addresses and requests simultaneously while data continues to move from previous requests on the main 32 data/address lines. Using SBA mode improves efficiency and reduces latencies.

AGP Specifications

The current PCI bus supports a data transfer rate up to 132 MB/s, while AGP (at 66MHz) supports up to 533 MB/s! AGP attains this high transfer rate due to its ability to transfer data on both the rising and falling edges of the 66MHz clock

Mode	Approximate clock rate	Transfer rate (MBps)
1x	66 MHz	266
2x	133 MHz	533
4x	266 MHz	1066
8x	533 MHz	2133

The AGP slot typically provides performance which is 4 to 8 times faster than the PCI slots inside your computer.

COMPONENTS OF GPU

There are several components on a typical graphics card:

Graphics Processor

The graphics processor is the brains of the card, and is typically one of three configurations:

Graphics co-processor: A card with this type of processor can handle all of the graphics chores without any assistance from the computer's CPU. Graphics co-processors are typically found on high-end video cards.

Graphics accelerator: In this configuration, the chip on the graphics card renders graphics based on commands from the computer's CPU. This is the most common configuration used today.

Frame buffer: This chip simply controls the memory on the card and sends information to the digital-to-analog converter (DAC) . It does no processing of the image data and is rarely used anymore.

Memory – The type of RAM used on graphics cards varies widely, but the most popular types use a dual-ported configuration. Dual-ported cards can write to one section of memory while it is reading from another section, decreasing the time it takes to refresh an image.

Graphics BIOS – Graphics cards have a small ROM chip containing basic information that tells the other components of the card how to function in relation to each other. The BIOS also performs diagnostic tests on the card's memory and input/ output (I/O) to ensure that everything is functioning correctly.

Digital-to-Analog Converter (DAC) – The DAC on a graphics card is commonly known as a RAMDAC because it takes the data it converts directly from the card's memory. RAMDAC speed greatly affects the image you see on the monitor. This is because the refresh rate of the image depends on how quickly the analog information gets to the monitor.

Display Connector – Graphics cards use standard connectors. Most cards use the 15-pin connector that was introduced with Video Graphics Array (VGA).

Computer (Bus) Connector – This is usually Accelerated Graphics Port (AGP). This port enables the video card to directly access system memory. Direct memory access helps to make the peak bandwidth four times higher than the Peripheral Component Interconnect (PCI) bus adapter card slots. This allows the central processor to do other tasks while the graphics chip on the video card accesses system memory.

Internal Organization of GPU

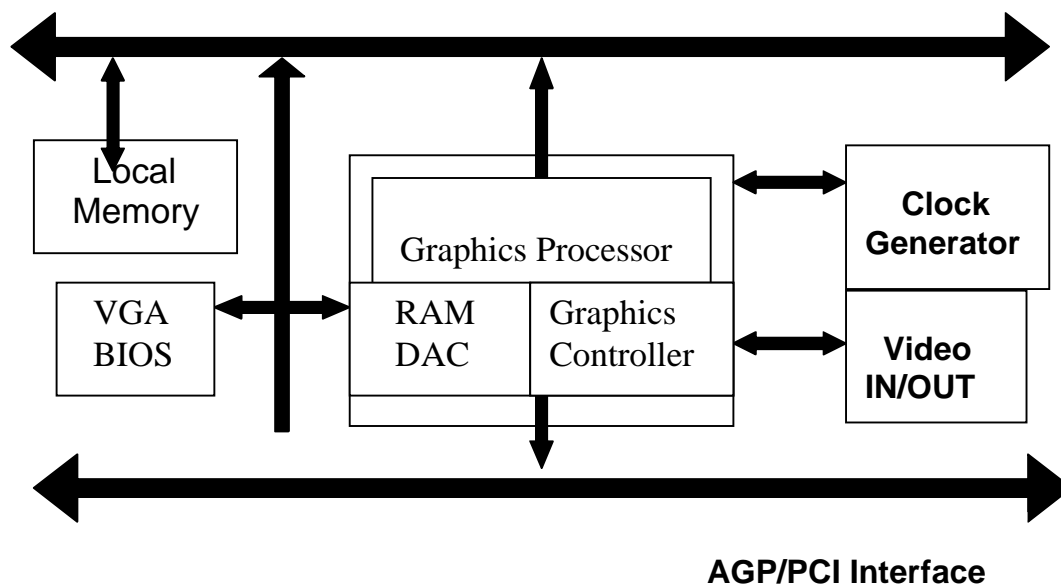

HOW IS 3D ACCELERATION DONE??????

There are different steps involved in creating a complete 3D scene. It is done by different parts of the GPU, each of which are assigned a particular job. During 3D rendering, there are different types of data that travel across the bus. The two most common types are **texture** and **geometry** data. The **geometry** data is the "infrastructure" that the rendered scene is built on. This is made up of polygons (usually triangles) that are represented by vertices, the end-points that define each polygon. **Texture** data provides much of the detail in a scene,

and textures can be used to simulate more complex geometry, add lighting, and give an object a simulated surface.

Many new graphics chips now have accelerated **Transform and Lighting (T&L) unit**, which takes a 3D scene's geometry and transforms it into different coordinate spaces. It also performs lighting calculations, again relieving the CPU from these math-intensive tasks.

Following the T&L unit on the chip is the **triangle setup engine**. It takes a scene's transformed geometry and prepares it for the next stages of rendering by converting the scene into a form that the pixel engine can then process. The **pixel engine** applies assigned texture values to each pixel. This gives each pixel the correct color value so that it appears to have surface texture and does not look like a flat, smooth object. After a pixel has been rendered it must be checked to see whether it is visible by checking the depth value, or Z value.

A **Z check unit** performs this process by reading from the Z-buffer to see if there are any other pixels rendered to the same location where the new pixel will be rendered. If another pixel is at that location, it compares the Z value of the existing pixel to that of the new pixel. If the new pixel is closer to the view camera, it gets written to the frame buffer. If it's not, it gets discarded. After the complete scene is drawn into the frame buffer the **RAMDAC** converts this digital data into analog that can be given to the monitor for display.

PERFORMANCE FACTORS OF GPU

There are many factors that affect the performance of a GPU. Some of the factors that are directly visible to a user are given below.

- **Fill Rate:**

It is defined as the number of pixels or texels (textured pixels) rendered per second by the GPU on to the memory . It shows the true power of the GPU. Modern GPUs have fill rates as high as 3.2 billion pixels. The fill rate of a GPU can be increased by increasing the clock given to it.

- **Memory Bandwidth:**

It is the data transfer speed between the graphics chip and its local frame buffer. More bandwidth usually gives better performance with the image to be rendered is of high quality and at very high resolution.

- **Memory Management:**

The performance of the GPU also depends on how efficiently the memory is managed, because memory bandwidth may become the only bottle neck if not managed properly.

- **Hidden Surface removal:**

A term to describe the reducing of overdraws when rendering a scene by not rendering surfaces that are not visible. This helps a lot in increasing the performance of GPU, by preventing overdraw so that the fill rate of the GPU can be utilized to the maximum.

Now lets see how far GPUs have come as far as performance is concerned.

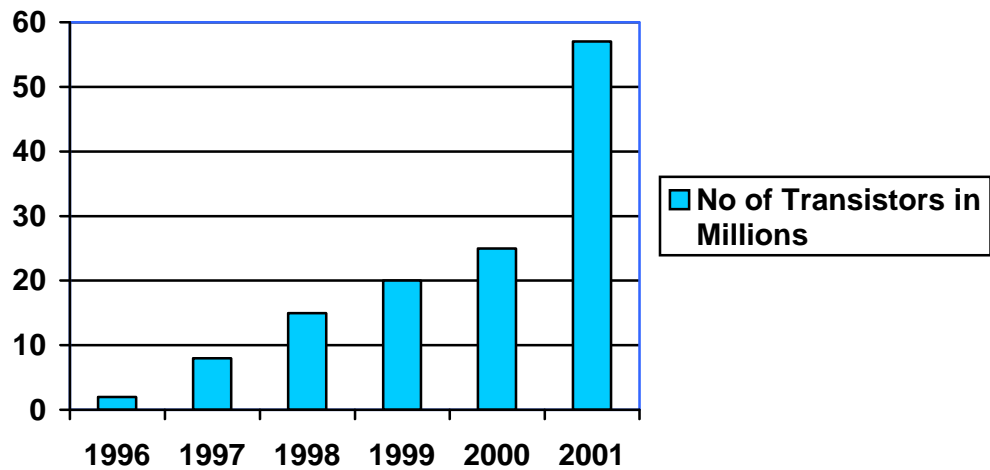
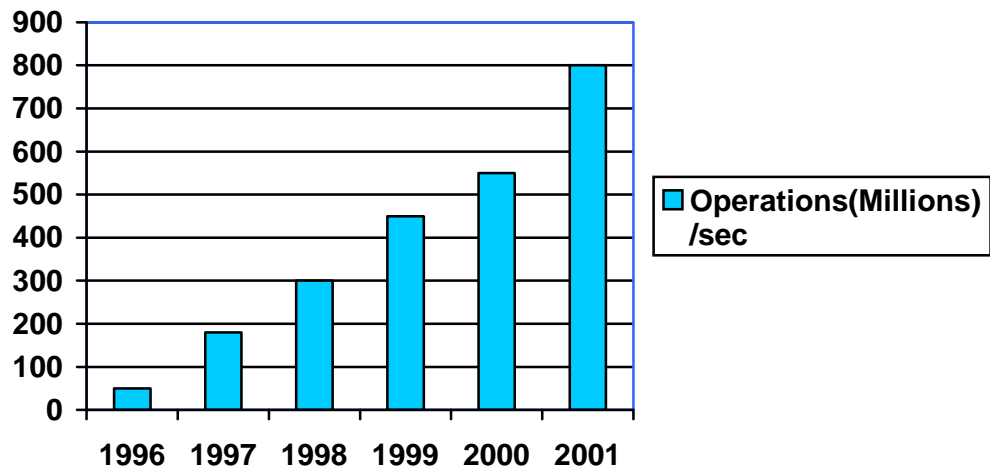

TYPES OF GPUS.....

There are mainly two types of GPUs, they are

1. Those that can handle all of the graphics processes without any assistance from the computer's CPU. They are typically found on high-end workstations. These are mainly used for Digital Content Creation like 3D animation as it supports a lot of 3D functions.

Some of them are.....

Quadro series from NVIDIA.

Wildcat series from 3D Labs.

FireGL series from ATI.

2. The chip on the graphics card renders graphics based on commands from the computer's CPU. This is the most common configuration used today. These are used for 3D gaming and such smaller tasks. They are found on normal desktop PCs and are better known as 3D accelerators. These support less functions and hence are cheaper.

Some of them are.....

Geforce series from NVIDIA.

Radeon series from ATI Technology ltd.

Kyro series from STM Microelectronics

Today's GPU can do what was hoped for and beyond. In the last year a giant leap have been made in the GPU technology. The maximum amount of RAM that can be found on a graphics card has jumped from 16MB to a whopping 128MB. The premier company in GPU manufacturing **ATI**, who has held the position past couple of years has given way to **nVidia**, whose new ground breaking technology is leaving ATI to follow.

GEFORCE4

NVIDIA introduced the groundbreaking, top-to-bottom GeForce4 family of GPUs—delivering new levels of graphics performance and display flexibility to desktop and mobile PCs. nVidia's latest creation, the GeForce4 GPU is the fourth edition in the famed GeForce lineup. It has wowed gamers and artists alike by having the capability to make graphics “better than life”

with 128MB of DDR memory and a super fast processor. What this means is that the GeForce4 is capable of rendering graphics better than the eye can see. Although this is extraordinary, there are no available monitors that can handle displaying such graphics. Even so, the nVIDIA GeForce4 is truly an extraordinary and groundbreaking graphics processing unit.

GeForce4 is the most complete family of graphics solutions—from the ferocious graphics power of the GeForce4 Ti, the world's fastest GPU; to the multi-display flexibility of the mainstream GeForce4 MX; to the most advanced mobile graphics available, GeForce4 Go.

Three of its kind has been released.....

- GeForce4 Ti series (NV25)
- GeForce4 MX series (NV17)
- GeForce4 Go series

Chip Architecture

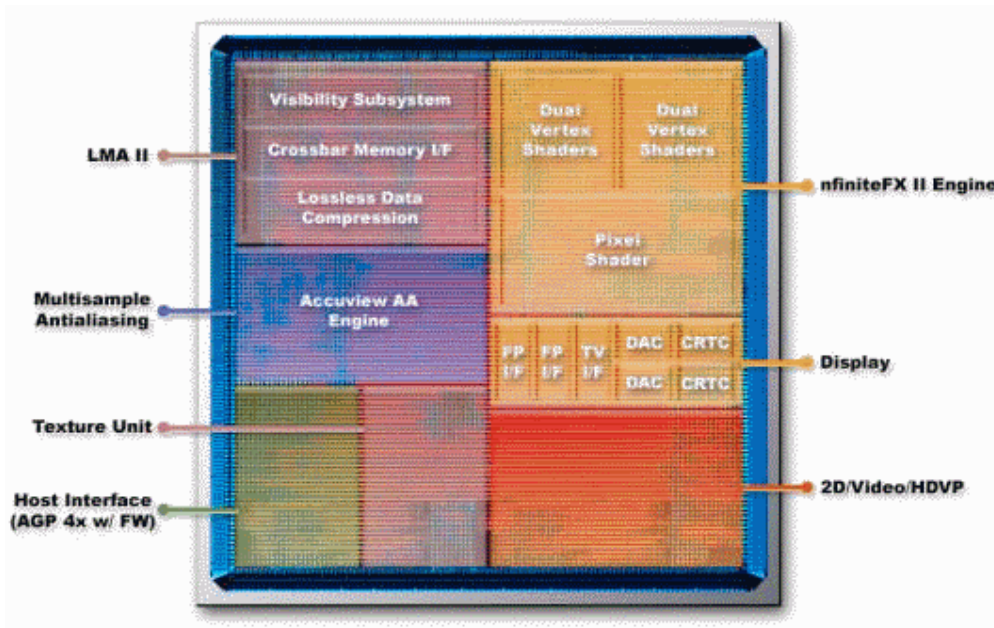

The LMA II

In the upper left hand corner lies the LMA II. The LMA II controls the flow of data from the chip to the GPU's memory (the DDR memory on the graphics card). It controls how much data is sent to the memory and how fast it is sent to the memory.

The Accuvview AA Engine

The Accuvview AA Engine, located to the left and in the middle of the chip, does the antialiasing for the GPU.

The Interface Unit

At the bottom of the GeForce4 chip and to the very left is the interface unit. This simply determines what interface (2X or 4X AGP) the computer has, and adjusts to comply with it.

The Texture Unit

At the bottom of the chip and to the left-center is the texture unit. This unit is dedicated to processing textures that must be rendered.

The nfiniteFX II Engine

This is the striking feature of GeForce4 series.

One among the classic computer graphics problem have been regarding the rendering the realistic hair and fur. Animals with skin texture were easy to render than those with fur.

For the first time ever, and only through the power of nfiniteFX II engine, which includes support for dual vertex shaders,advanced pixel shader pipelines , 3D textures, shadow buffers and z-correct bump mapping ,is it now possible to render those.

It also improves rendering of shading.



A demo shot of a wolf man which has been rendered by GeForce4

The Display Unit

In the center to the right of the chip is the display unit. This unit is simple and its only job is to determine the optimal display resolution for the display being used. It also determines what type of display it is and optimizes its performance.

The 2D/Video/HDVP Unit

In the bottom right corner of the chip is the 2D/Video/HDVP unit. This part of the chip is dedicated to all those tasks that don't require 3D rendering. These tasks include movies, 2D pictures, 2D games and almost any other program that doesn't have 3D graphics

nView Technology:

Simply put, NVIDIAs Multi-Monitor and Dual Independent Display technology, now called "nView", has been polished up nicely. nView is available on both the GF4 Ti and MX and enables the following:

Multi-desktop tools

- Multi-desktop integration
- Full featured interface including explorer browser with birds-eye views of desktops
- Toolbar control available as well for those needing a streamlined, low real- estate interface

Window management

- Individual application control
- Window & dialog repositioning

Application management

- Transparency & colored transparency window options
- Extends functionality of all applications
- Pop- up menu control

GEFORCE4 TI

nVIDIA's crown graphics card is the GeForce4 Ti, a creation of admirable brilliance. Its basic specifications include

- 63 million transistors (only 3 million more than GeForce3)
- Manufactured in TSMC's .15 μ process
- Chip clock 225 - 300 MHz
- Memory clock 500 - 650 MHz
- Memory bandwidth 8,000 - 10,400 MB/s
- TnL Performance of 75 - 100 million vertices/s
- 128 MB frame buffer by default
- nfiniteFX II engine
- Accuvision Anti Aliasing
- Light Speed Memory Architecture II
- nView

It has a 128 bit bus , double the size of previous busses and the only graphics card to have one. This extra bus size improves performance dramatically. Its considered as the **world's fastest GPU** available today.

NV25 series include four- GeForce4 Ti 4600 ,GeForce4 Ti 4400 , GeForce4 Ti 4200 & GeForce4 Ti 4200 w/AGP 8x



This chart shows comparison of performances of GeForce4 Ti 4600 and its predecessor in FPS.

GEFORCE4 MX

With the GeForce4 MX graphics processing units (GPUs), NVIDIA provides a new level of cost-effective, high-performance graphics to the mainstream PC user. The GeForce4 MX is the cheapest and worst performing of the three lines. The standard graphics card comes with 64MB of RAM, a hefty amount that can handle almost any task. The GeForce4 MX has a 64bit bus, which is also pretty standard for today's graphics cards. For the most part the only real improvement from the GeForce3 MX to the GeForce4MX is the graphics processing unit, which beats its predecessors, the GeForce2 and GeForce3, hands down.

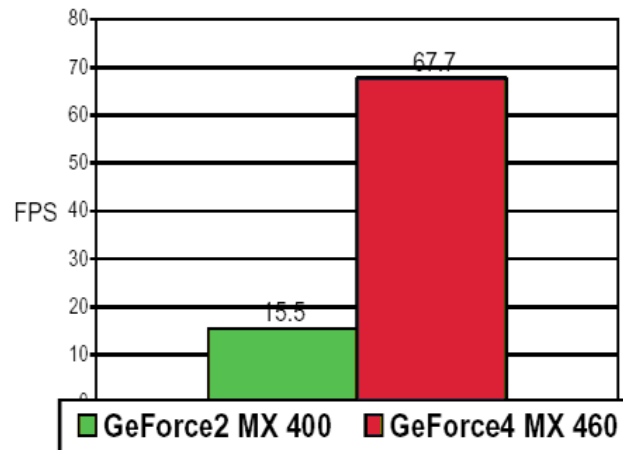

Performance comparisons

GEFORCE4 GO

NVIDIA introduces the fastest, most comprehensive and feature-rich computing experience ever realized on a mobile platform— the GeForce4 Go. With a revolutionary core of integrated technologies, the GeForce4 Go ensures unparalleled performance, battery life, and DVD and video playback. From notebooks powerful enough to replace your desktop PC, to those that are both

thin and light, NVIDIA's GeForce4 Go mobile GPUs provide unprecedented mobile computing experiences.

CONCLUSION

From the introduction of the first 3D accelerator from 3dfx in 1996 these units have come a long way to be truly called a “Graphics Processing Unit”. So it is not a wonder that this piece of hardware is often referred to as an exotic product as far as computer peripherals are concerned. By observing the current pace at which work is going on in developing GPUs we can surely come to a conclusion that we will be able to see better and faster GPUs in the near future.

3D GLOSSARY

Given below are some of the terms that are closely associated with GPUs .

Vertex: Vertices are the “basic unit” of 3D graphics. All 3D geometry is composed of vertices. Vertices contain X, Y and Z positions plus possible vertex normal and texture mapping information.

Polygons or Triangles:

3D scenes are drawn using only triangles. This vastly simplifies the computer creation of a 3D world. Triangles are defined as three x,y,z coordinates (one for each vertex), a properly-oriented texture, and a shading definition. The illusion of curved surfaces (fuselage, engines, wings, etc.) comes from well-applied shading of a flat polygon. A good 3D-accelerator card will put the textures together without any seams, white pixels that flash where the triangles almost meet.

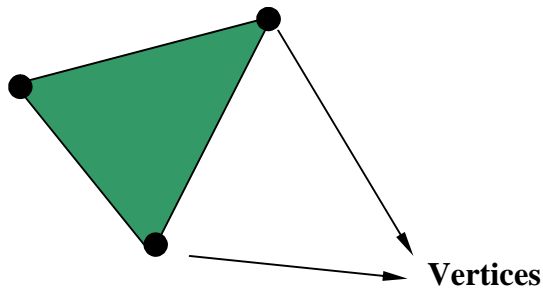

A basic triangular polygon

Texture (Bitmap):

A Texture Map is a way of controlling the diffuse color of a surface on a pixel-by-pixel basis, rather than by assigning a single overall value. This is commonly achieved by applying a color bitmap image to the surface.

Rasterization:

The process of finding which pixels an individual polygon covers or, at a more basic level, on which pixels an edge of a polygon lies on. This second aspect will be dealt with first. Simply, it is the process of transforming a 3D image into a set of colored pixels.

Rendering:

A term which is often used as a synonym for rasterization, but which can also refer to the whole process of creating a 3D image. Rendering is the process of producing bitmapped images from a view of 3-D models in a 3-D scene. It is, in effect, "taking a picture" of the scene. An animation is a series of such renderings, each with the scene slightly changed

Anti-aliasing:

A method to remove the jagged edges that appear in the computer generated images.

Filtering:

Filtering is a method to determine the color of a pixel based on texture maps. When you get very close to a polygon the texture map hasn't got enough info to determine the real color of each pixel on the screen. The basic idea is interpolation; this is a technique of using information of the real pixels surrounding the unknown pixel to determine its color based on mathematical averages.

Following are some methods of filtering starting (from the worst quality to best)

1. Point Sampled filtering
2. Bilinear filtering

3. Trilinear filtering

Point filtering will just copy the color of the nearest real pixel, so it will actually enlarge the real pixel. This creates a blocky effect and when moving this blocks can change color quickly creating weird visual effects. This technique is always used in software 3D engines because it requires very little calculation power.

Bilinear filtering uses four adjacent texels (textured pixels) to interpolate the output pixel value (unknown). This result in a smoother textured polygon as the interpolation filters down the blockiness associated with point sampling. The disadvantage of bilinear texturing is that it results in a fourfold increase in texture memory bandwidth.

Trilinear filtering will combine Bilinear filtering in 2 Mip levels. This however results in 8 texels being needed so memory bandwidth is multiplied by 2. This usually means that the memory will suffer serious bandwidth problems so trilinear filtering is usually used as an option.

Alpha-blending:

It is a technique to do transparency. It is an extra value added to the pixels of a texture map to define how easy it is to look through the pixel. This way it is possible to look through things and effects like realistic water and glass are possible.

FPS:

FPS stands for Frames per Second. This is the main a unit of measure that is used to describe graphics and video performance.

Texture Mapping:

In 3D graphics, texture mapping is the process of adding a graphic pattern to the polygons of a 3D scene. Unlike simple shading, which uses colors to the underlying polygons of the scene, texture mapping applies simple textured graphics, also known as patterns or more commonly "tiles", to simulate walls, floors, the sky, and so on.

T&L:

Transform and lighting (T&L) are two major steps in the 3D graphics pipeline. They are computationally very intensive. Transform phase converts the source 3D data to a form that can be rendered and Lighting phase calculates lighting for the 3D environment. These two steps can be performed simultaneously or consequently to a triangle. Traditionally the CPU performs them, but nowadays some 3D accelerators also have dedicated hardware T&L solutions

Frame buffer:

The memory used to store the pictures you see on screen. Under Direct3D, there are actually two frame buffers. The front buffer is being displayed while the back buffer is being drawn. When the back buffer is complete it becomes the new front buffer and the old front buffer is cleared and the next frame is drawn there. (This method of buffering is being referred as **double buffering**).

Triple buffering:

Here three buffers are used instead of two. If you have very fast refresh rates there isn't much wait for the buffer swap. But if you have slow refresh rates, the wait can be considerable. To stop this, 3Dfx drivers (for the Rush and Voodoo2) can enable a third frame buffer, so when it is done with the back buffer it starts immediately on the next one.

Z-Buffer:

A third buffer (or a fourth if triple buffering is enabled) where depth data is stored, to help hardware to sort out which textures are visible and which are hidden.

API (Application Program Interface):

It is a set of routines, protocols, and tools for building software applications. A good API makes it easier to develop a program by providing all the building blocks. Game programmers use Application Programming Interfaces to help them program 3D functions more easily and so the program they write will run on more types of hardware.

The three most popular graphical API's (Application Programming Interface's) are:

- GLide by 3dfx,
- OpenGL by Silicon Graphics (and Microsoft), and
- Direct3D by Microsoft as part of their multimedia DirectX package.

REFERENCES

1. www.howstuffworks.com
2. www.tomshardware.com
3. www.intel.com
4. www.nvidia.com
5. www.extremetech.com
6. www.pcworld.com

ACKNOWLEDGEMENT

I extend my sincere thanks to **Prof. P.V.Abdul Hameed**, Head of the Department for providing me with the guidance and facilities for the Seminar.

I express my sincere gratitude to Seminar coordinator **Mr. Berly C.J**, Staff in charge, for their cooperation and guidance for preparing and presenting this seminar.

I also extend my sincere thanks to all other faculty members of Electronics and Communication Department and my friends for their support and encouragement.

Anish Salam

CONTENTS

1. INTRODUCTION
2. WHAT'S A GPU ???
3. HISTORY AND STANDARDS
4. PERIPHERAL COMPONENT INTERCONNECT
5. ACCELERATED GRAPHICS PORT
6. COMPONENTS OF GPU
7. HOW IS 3D ACCELERATION DONE ?
8. PERFORMANCE FACTOR OF GPU
9. TYPES OF GPU
10. GEFORCE4
11. GEFORCE4 TI
12. GEFORCE4 MX
13. GEFORCE4 GO
14. CONCLUSION
15. 3D GLOSSARY
16. REFERENCES

ABSTRACT

A Graphics Processing Unit (GPU) is a microprocessor that has been designed specifically for the processing of 3D graphics. The processor is built with integrated transform, lighting, triangle setup/clipping, and rendering engines, capable of handling millions of math-intensive processes per second. GPUs allow products such as desktop PCs, portable computers, and game consoles to process real-time 3D graphics that only a few years ago were only available on high-end workstations. Used primarily for 3-D applications, a graphics processing unit is a single-chip processor that creates lighting effects and transforms objects every time a 3D scene is redrawn. These are mathematically-intensive tasks, which otherwise, would put quite a strain on the CPU.